

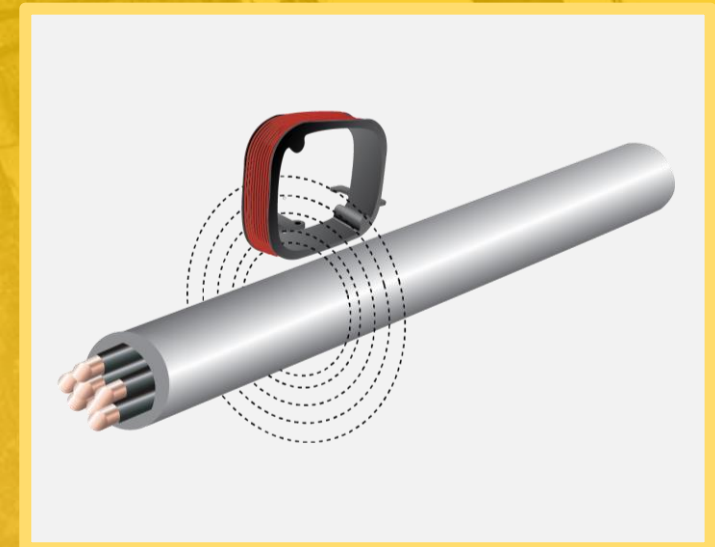

# The Theory of Pipe and Cable Locating

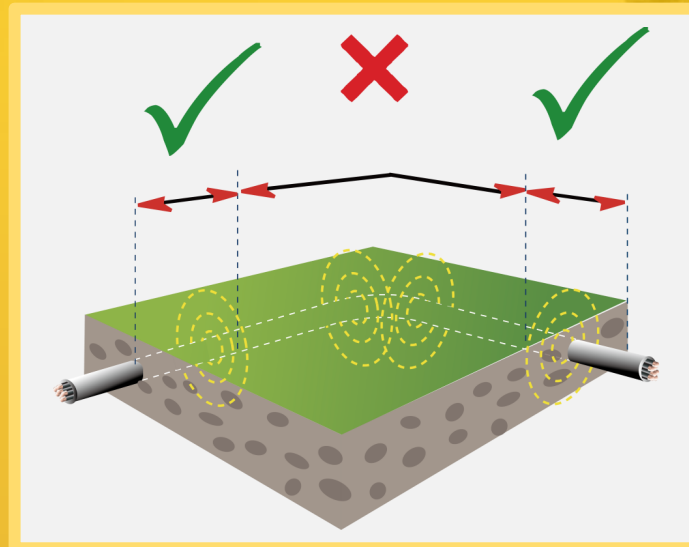

# Typical Utility (Line) Locators

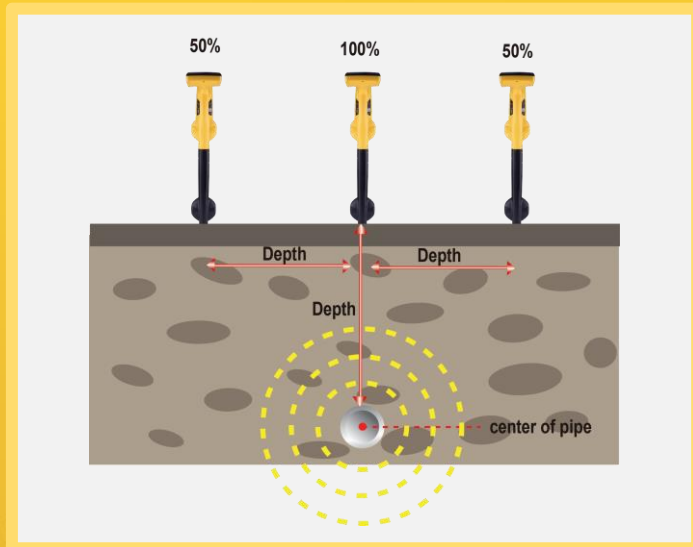

# What are Utility Locators?

The typical utility locator consists of a Receiver and Transmitter. The transmitter will come with a set of Direct Connection Leads and Ground Stake to connect to the utility.



**Receiver**



**Transmitter**



Ground stake



Direct  
Connection  
Leads

# Accessories

A popular accessory usually sold with the transmitter is a Signal Clamp. Sometimes the signal clamp can be used in place of the direct connection leads.



**Transmitter**

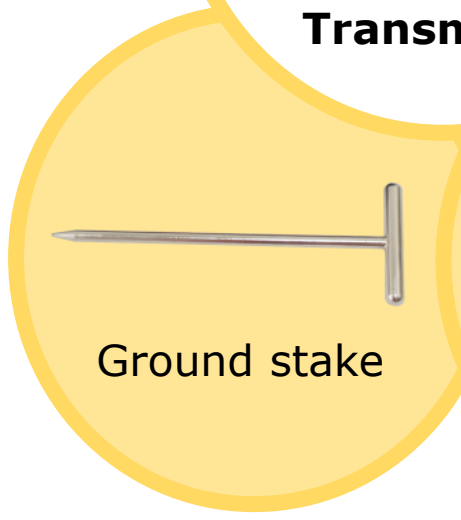

Ground stake

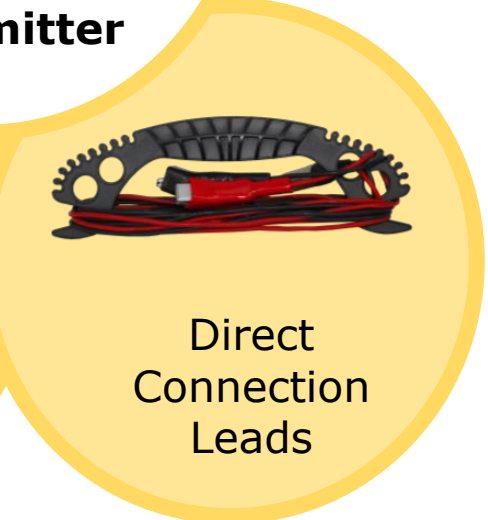

Direct  
Connection  
Leads

# The Locate Signal



# The Locate Signal

Electromagnetic Locators **do not** locate buried pipes or cables,

Locators **detect the electromagnetic signals** radiating from metallic pipes and cables.

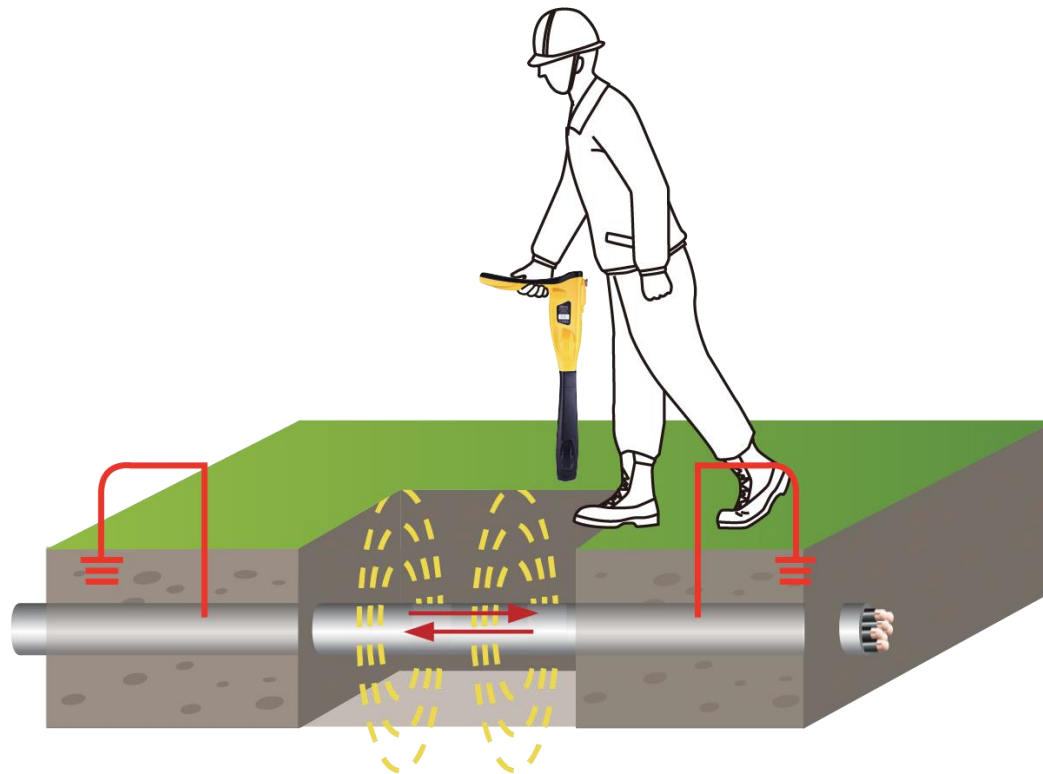

# The Locate Signal

- Is produced by the flow of alternating current (**AC**), which creates an electromagnetic field
- This electromagnetic field **radiates from** the line and is known as the signal

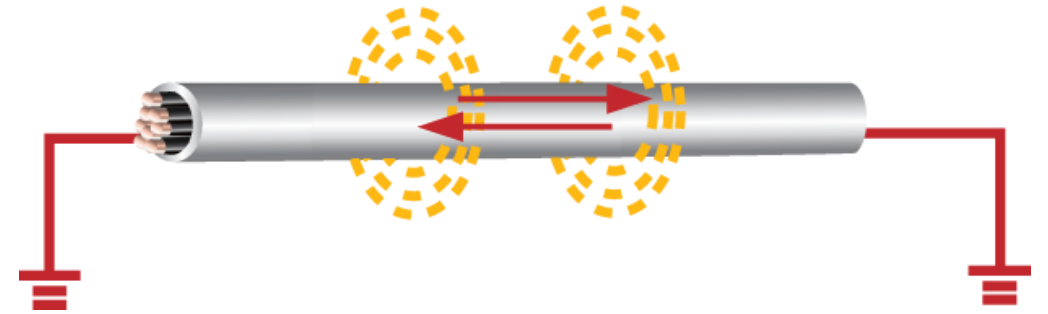

If there is **no AC current flowing**, there will be **no locate signal**

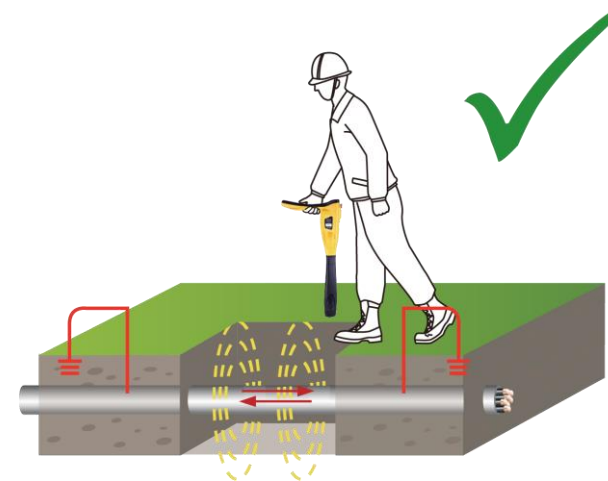
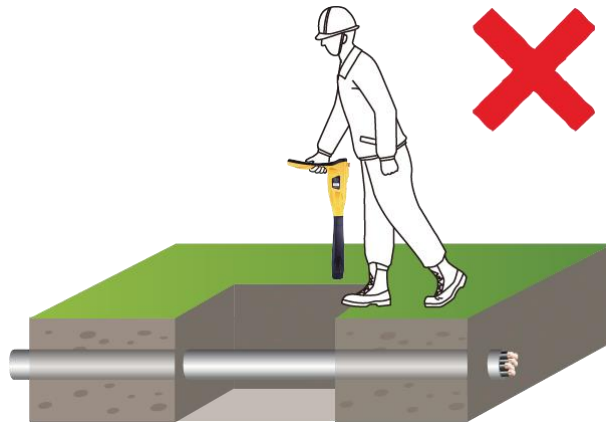

# The Locate Signal

- Signals are created by current flowing from the transmitter, traveling along a conductor (line/cable/pipe) and back to the Ground Stake.
- We think of the signal traveling from the transmitter and back to the ground stake. However, the signal is continually changing direction, flowing back and forth.
- The rate at which it changes direction is called the frequency. For example, 50Hz means the signal changes direction 50 times per second, 8000Hz (or 8 kHz) means 8000 times per second. (The "k" denotes 1000).

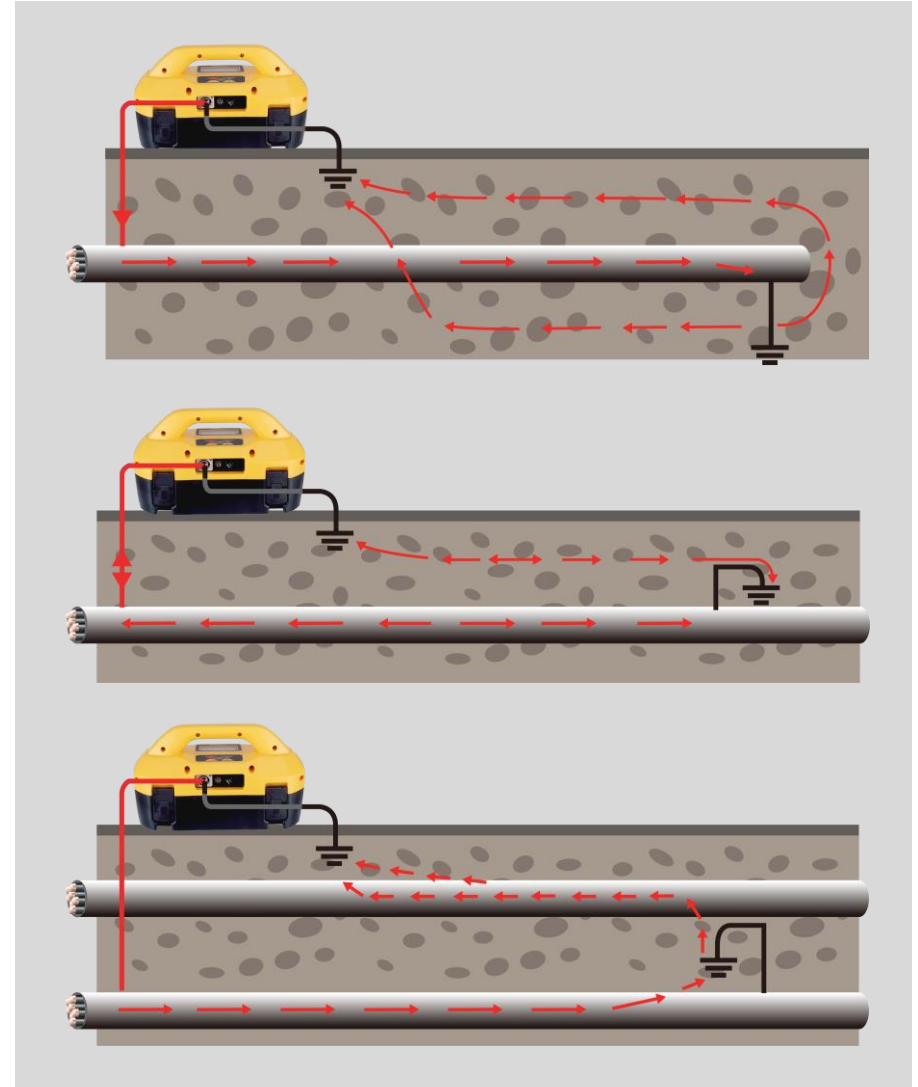

# Signal Sources



# Signal Sources

Signals used for locating can originate from a transmitter (**active locating**) or a variety of passive sources (**passive locating**).

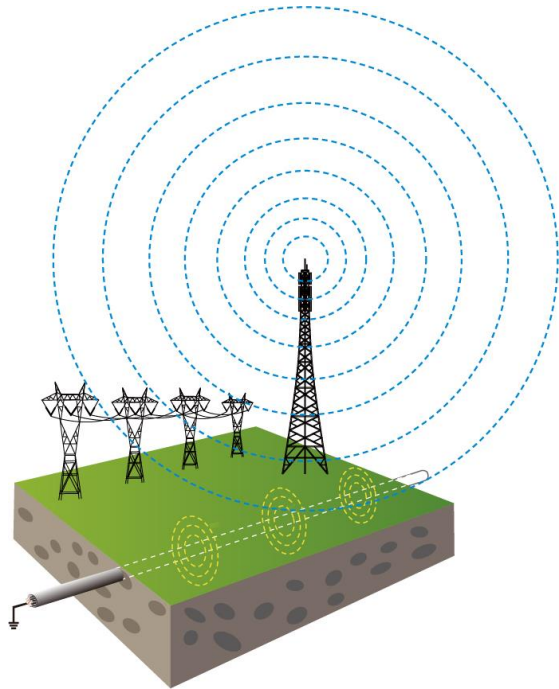

**Passive Sources can be Power and Radio signals induced onto the utilities**

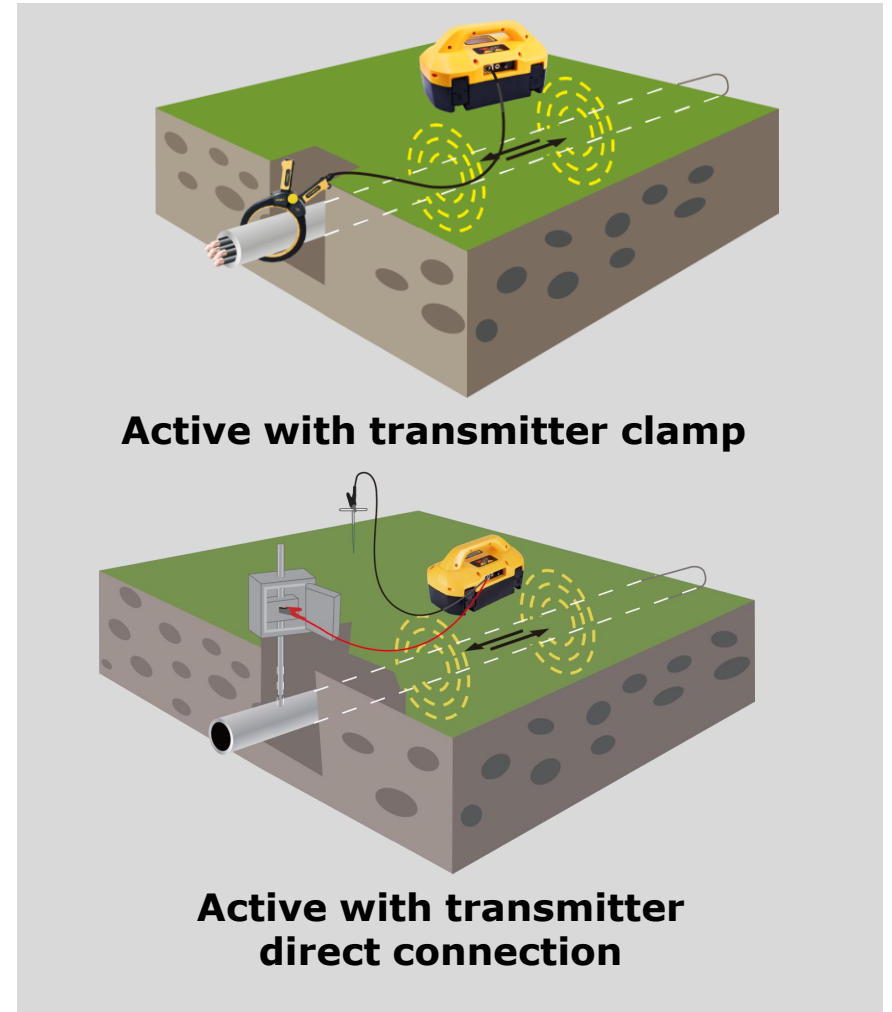

- **Passive Location**

- Use to mark the location of unidentified buried lines before digging (Avoidance)



- **Do not** use to identify or trace specific lines

- **Active Location**

- Use to trace, identify & pinpoint a buried line
- Use to measure the depth estimation of the buried line
- Use to measure the signal current on the buried line

# Passive Signal Sources



# Passive Signals

- **Power**

Power transmission & distribution networks (50/60Hz & related harmonics)

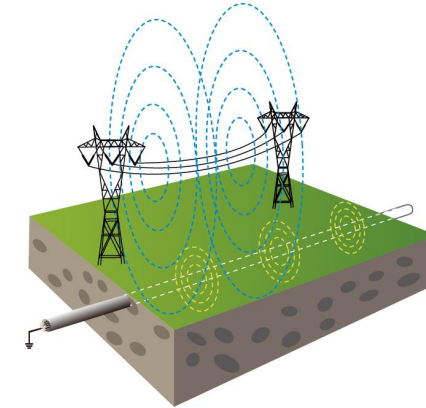

- **Radio**

Radio transmissions (15 kHz – 27 kHz & related harmonics)

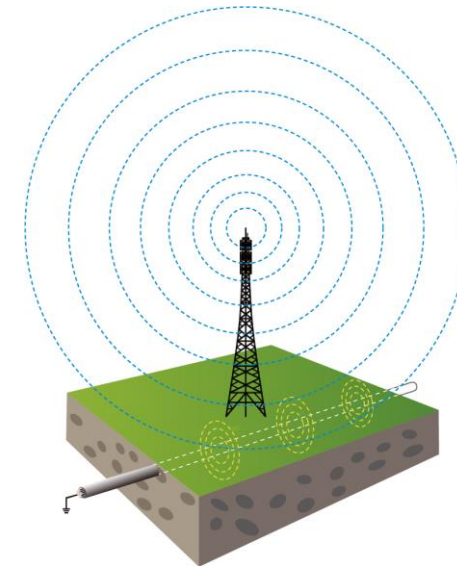

- **Application specific**

Signals from specific applications (Cathodic protection, CATV, etc.)

# When to Use Passive Modes

- Search for unknown buried lines when applying signal with a Transmitter is not practical
- For small localized digging
- The last check before digging



Always **Call Before You Dig**, follow local Government regulations and your company's safety and best practices.



Know what's **below**.  
Call **811** before you dig.

## Power Signals

- From cables carrying electric current and under load
- From pipes or other cables carrying return electric current
- Cables may be live; however, **no** current is visible because of no load.

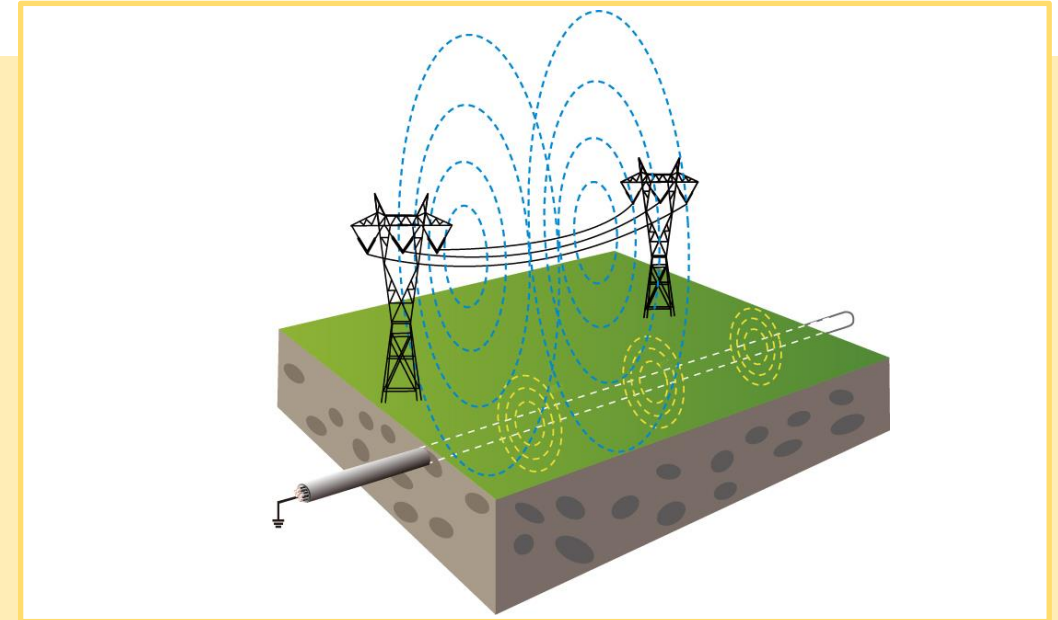

## Radio Signals

- Mainly generated by high power, low frequency (LF) communication transmitting towers
- Buried pipes and cables act as conductors that re-radiate the signal
- Radio signals travel further distances if both ends of the utility are grounded

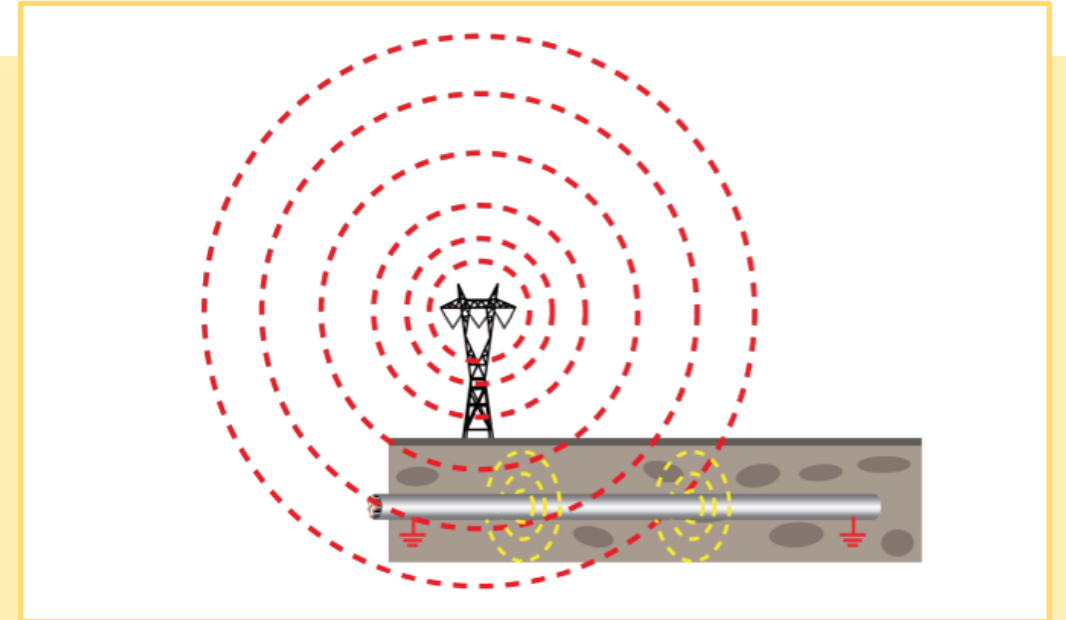

## Application-Specific

- Some Pipes have a Cathodic Protection current on them to protect against corrosion. This may be detectable with CP120 or CP100 frequencies.

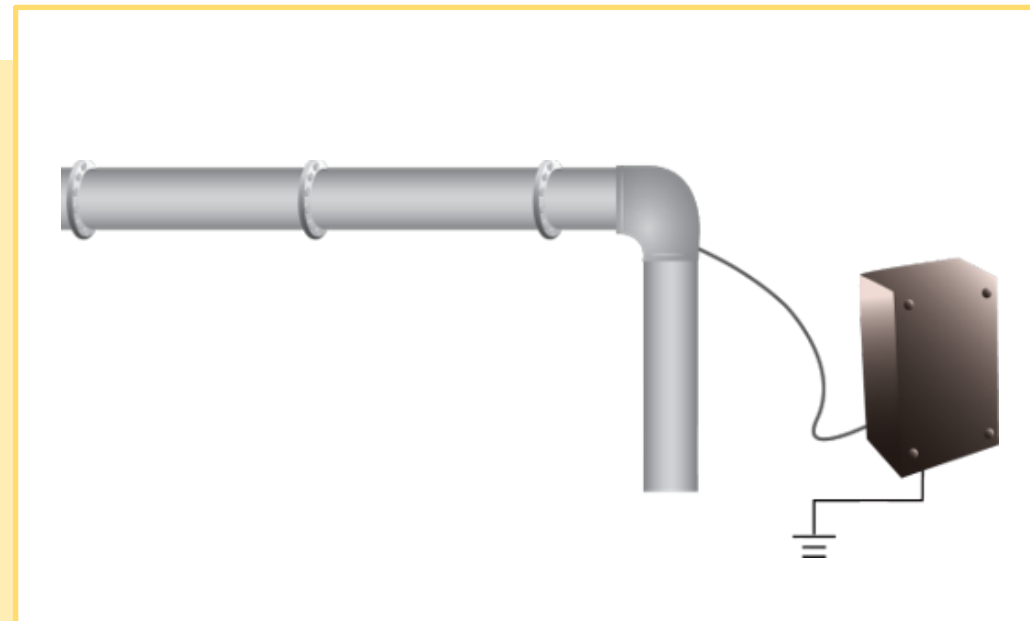

# Passive Locating - Passive Sweep

- Passive locating is used to **avoid** rather than identify buried lines
- Using only the receiver, sweep the area in a pattern shown here
- Sweep in **Power** modes and **Radio** modes

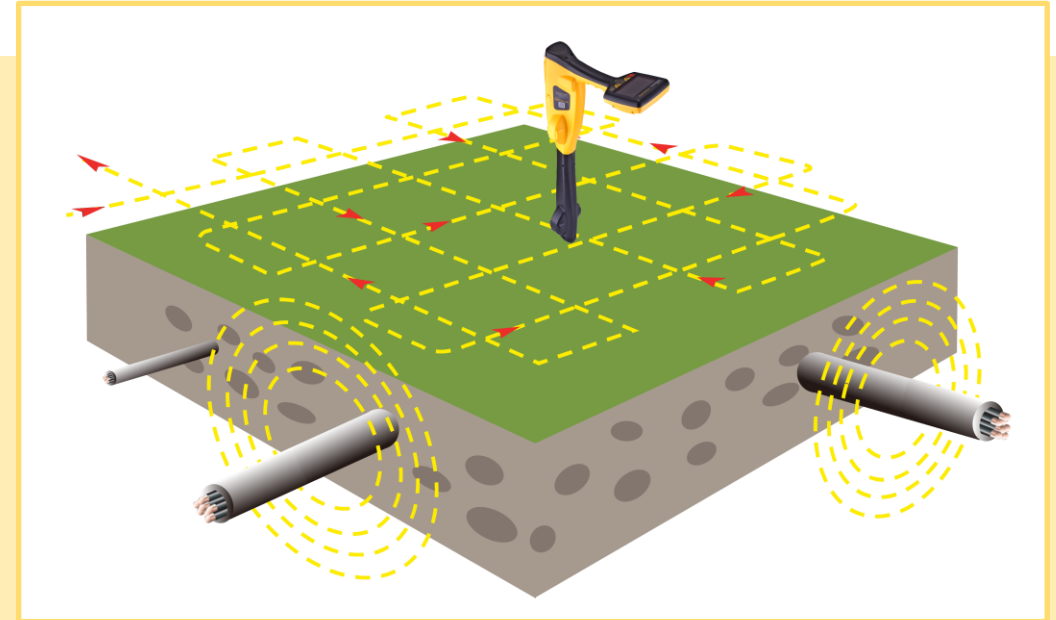

# Active Signal Sources



## A transmitter applies active signals

- Transmitters have one or more dedicated frequencies
- The choice of frequency depends on the line being located and the method the signal is applied

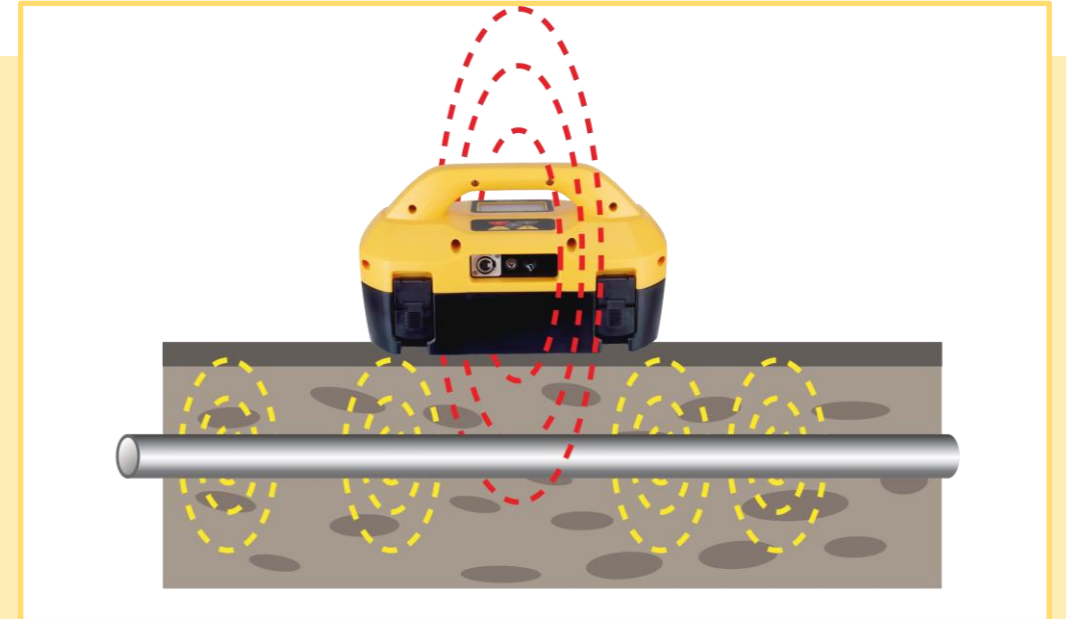

# When to Use Active Modes

- Use to trace, identify & pinpoint a buried line
- Use to measure the depth of the buried line
- Use to measure the signal current on the buried line



Always **Call Before You Dig**, follow local Government regulations and your company's safety and best practices.



Know what's **below**.  
Call 811 before you dig.

# Active Signals - Applying

**Direct connection** – red lead to the target line, black lead to ground

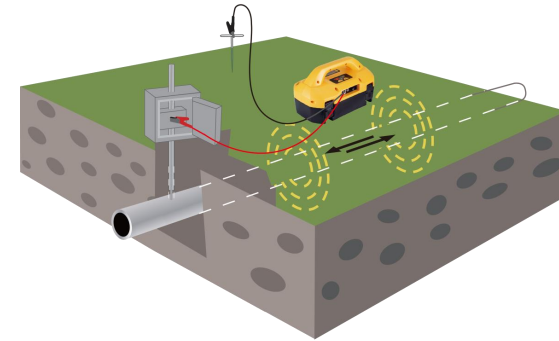

**Clamp** – induces a signal into a pipe or cable without making a direct connection

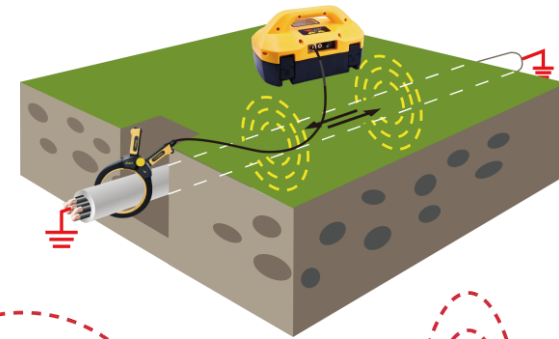

**Induction** – induces the signal onto a pipe or cable by placing the transmitter on the surface over the target line

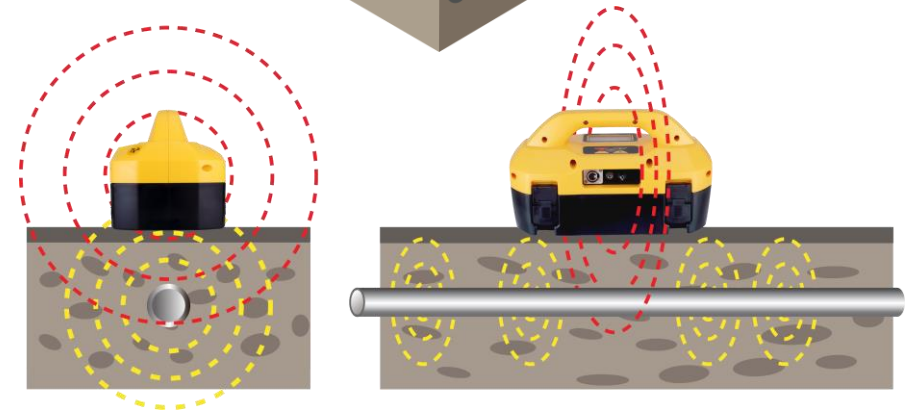

# Active Locating

- Active location is used to **trace and pinpoint** a specific buried line
- Active location always requires a transmitter and receiver.



\* **Tracing is following the path of the buried line from, or to the transmitter**

# Transmitter - Connection Types



# Transmitter - Connection Types

There are three ways to apply the signal:

**Direct connection** – Red cable to the target line, Black to the ground Stake

**Induction** – induces a signal onto a cable or pipe by placing the transmitter on the surface over the target line

**Clamp** – induces a signal onto a cable without making a direct connection

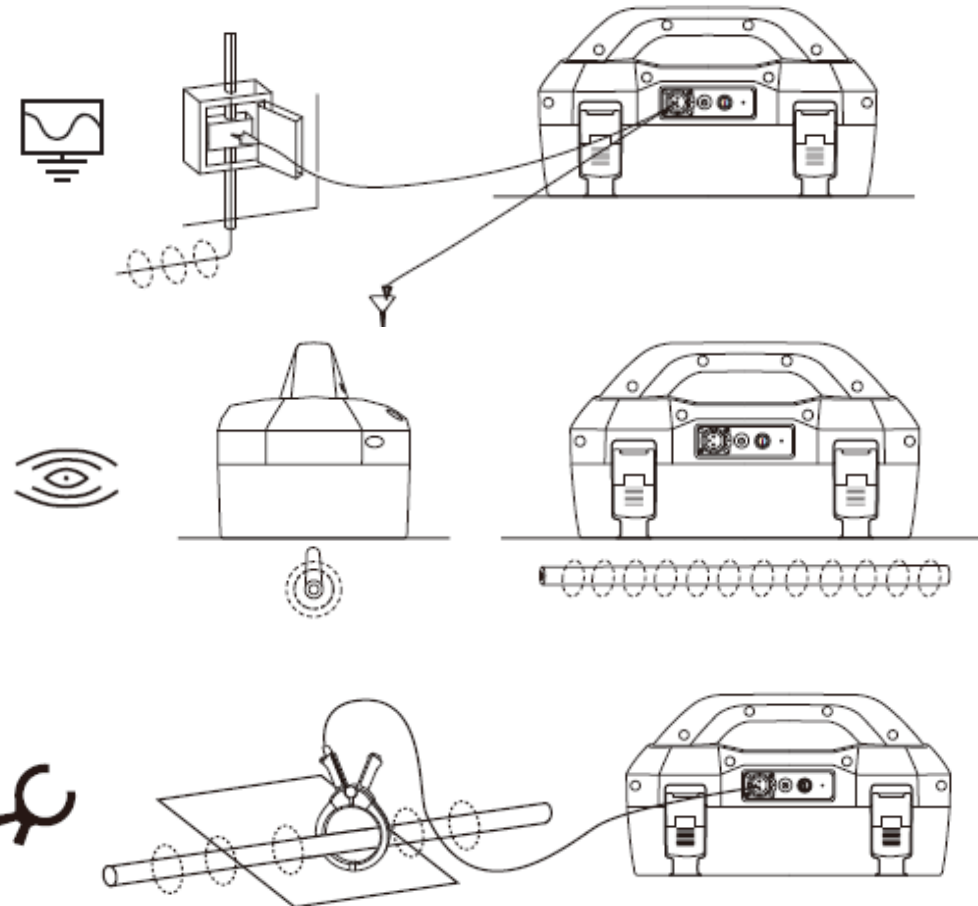

## Direct connection

- Use the minimum output power needed to locate the target line successfully
  - Excess power may increase the risk of coupling to other lines
  - Using excess power can make locating more complex and increases the risk of mis-locating
  - More power reduces battery life
  - The transmitter display will confirm how much current is being applied to the line indicating a good or bad connection
  - A change in speaker tone also confirms a good or bad connection
  - If the display shows no current or there is no change of speaker tone, check the connection to the target line



## Direct connection

- Direct connection is the preferred method of connecting to a utility when there is safe access to the target line
- Remove any rust or paint to ensure a good electrical connection
- Place the ground stake in the ground at 90° to the cable and as far away as practical

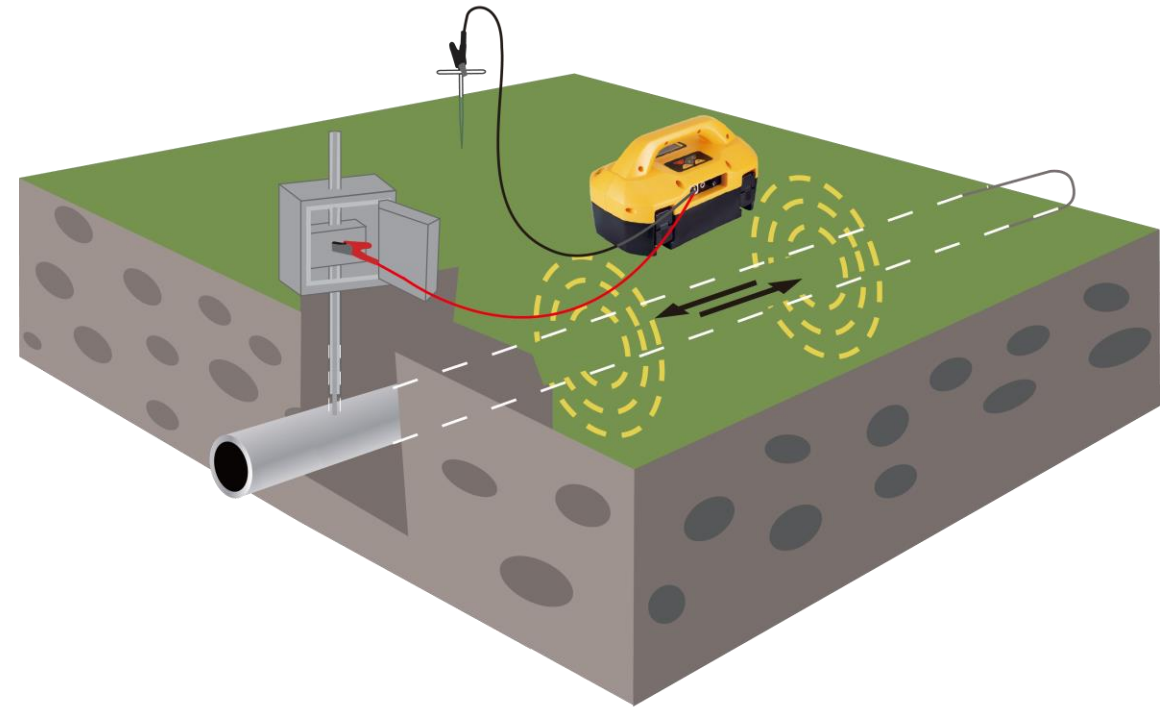

## Direct connection

- When positioning the ground stake – to minimize coupling to other lines
- Do **not** place it close to other lines
- Do **not** place it on the other side of adjacent lines
- Do **not** place it close to metallic fences or barriers

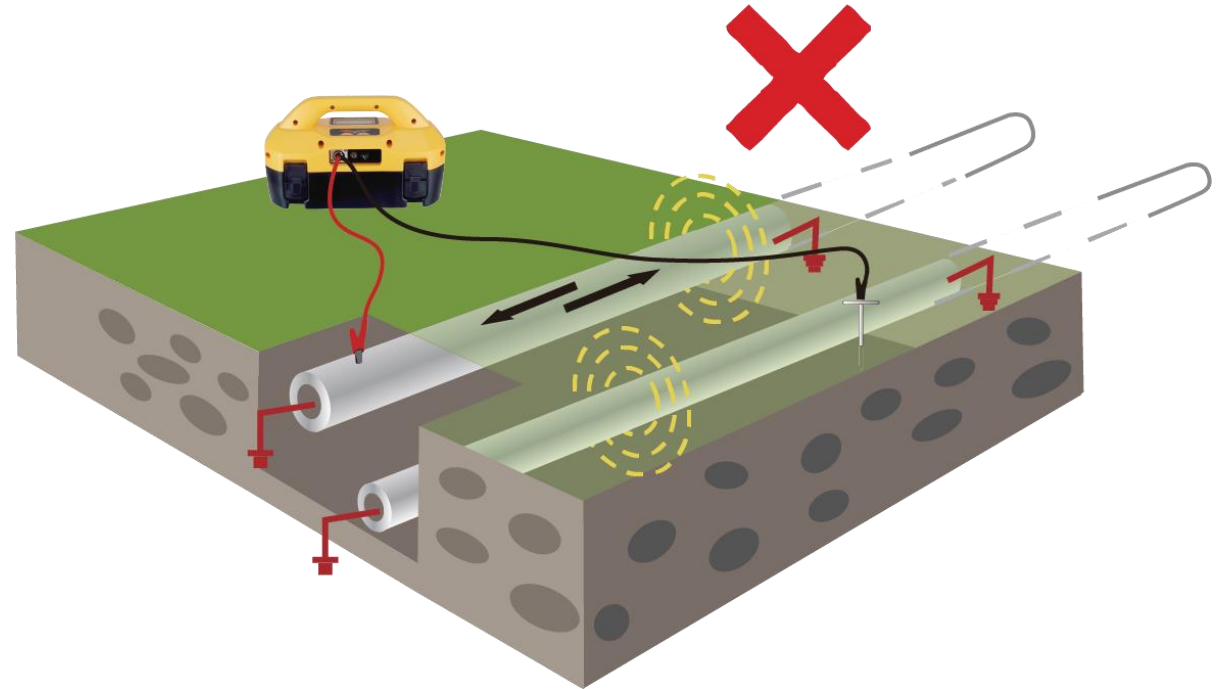

# Applying The Transmitter Signal - Signal Clamp

## Using a Signal Clamp

- Use when you cannot directly connect to a utility
- Place the clamp around the utility.
- Connect below the grounding point
- The utility line must be grounded at each end.

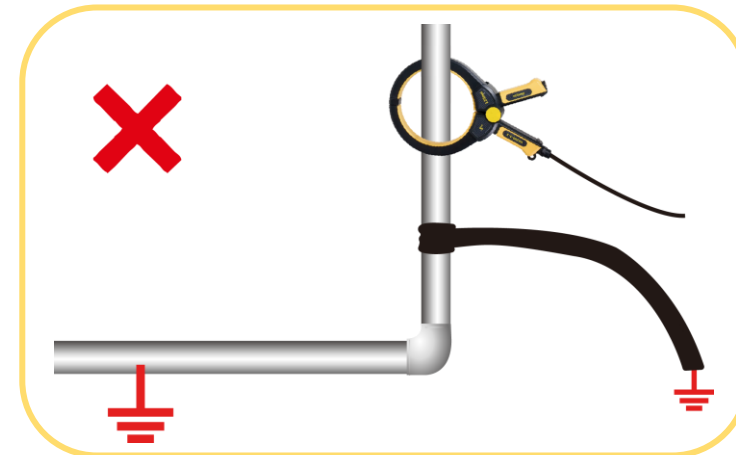
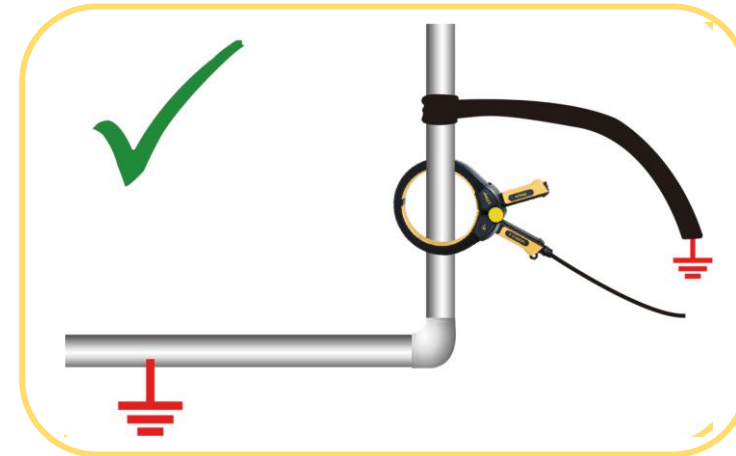

\* Clamps are designed for specific frequencies only, typically 8 kHz – 83 kHz

## Induction

- Allows signal to be applied without access to the line
- The applied signal, or current, is generally less than the other connection methods (as it has to travel through the ground to reach the line)
- It may couple to other metallic lines & structures adjacent to the target line

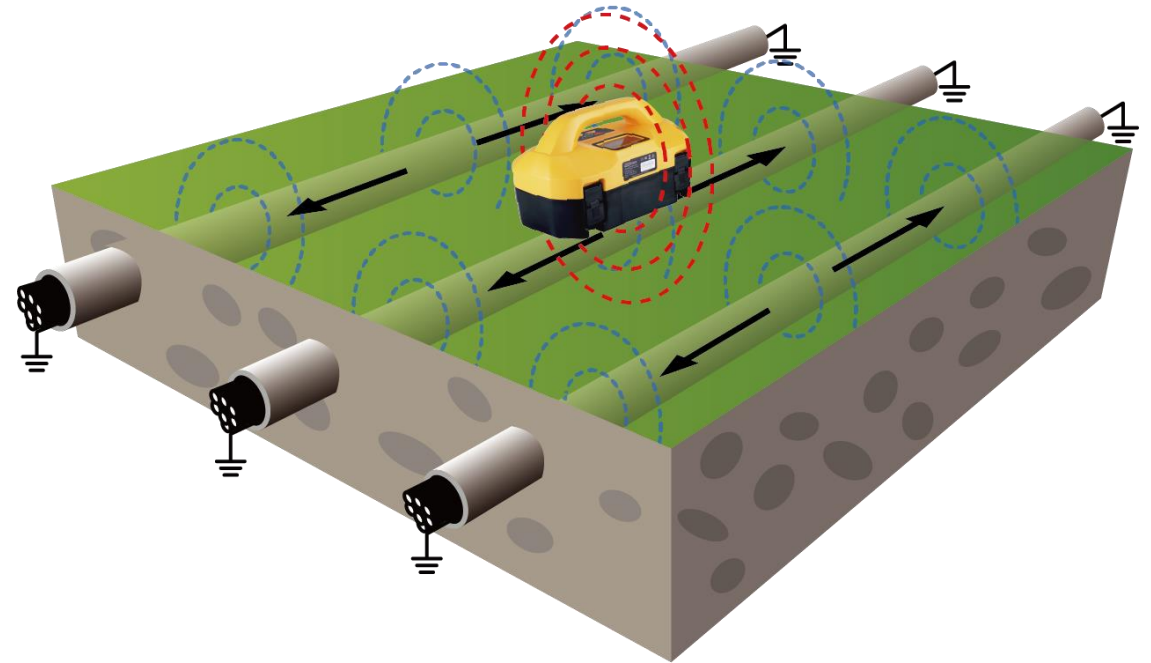

## Induction

- Place the transmitter over and in line with the target line at a known point (but not on top of an access point such as a maintenance hole, handhold or pedestal)
- Ensure the transmitter is oriented correctly

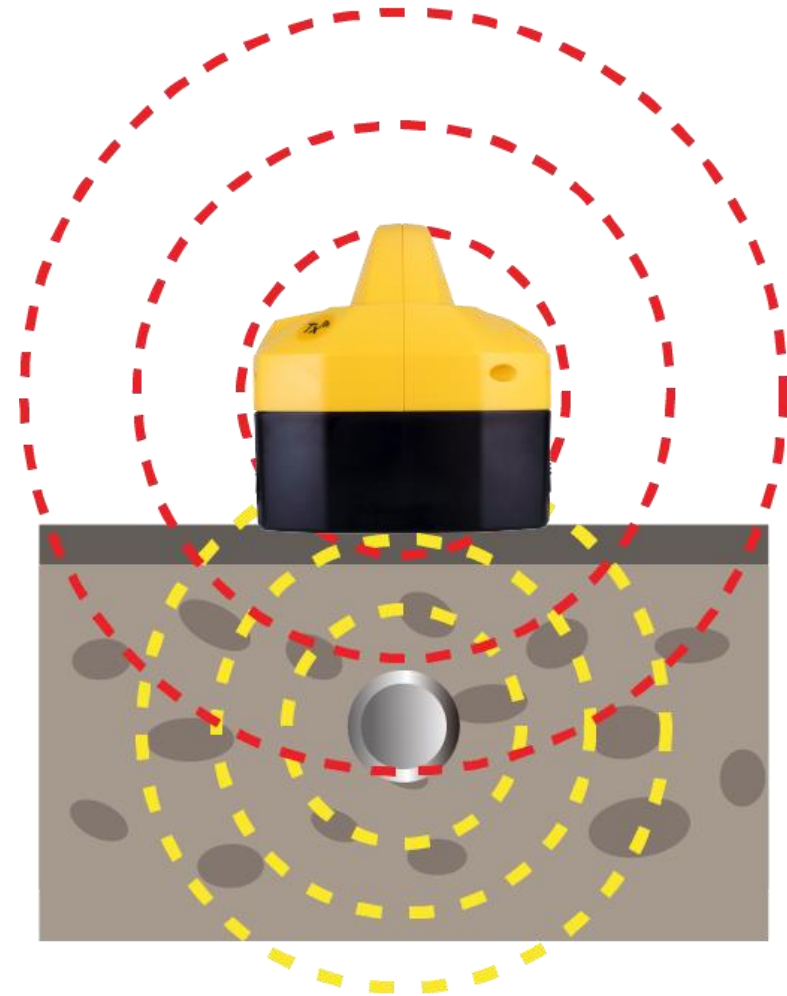
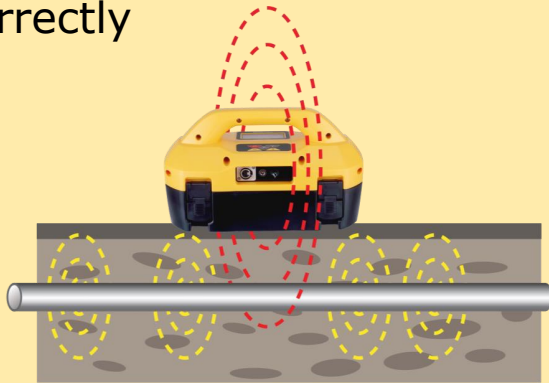

# Applying The Transmitter Signal - Induction



Move at least 65ft (20m) away from the transmitter to avoid picking up the signal through the air.



Do not place on top of a manhole cover or metal plate (the signal will be absorbed by the metal)

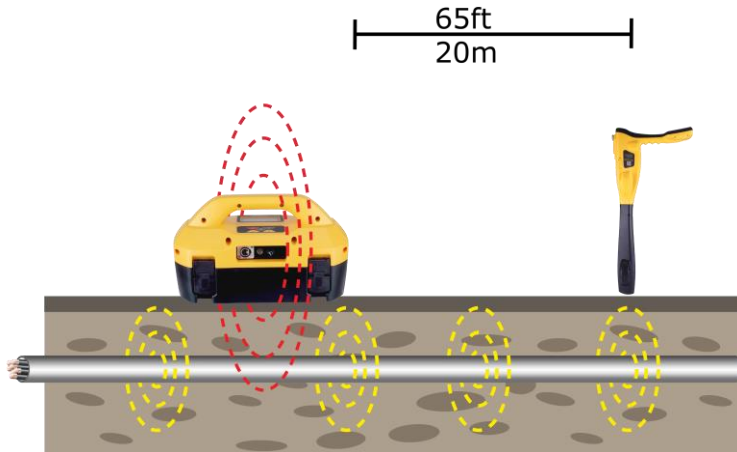

**Induction**

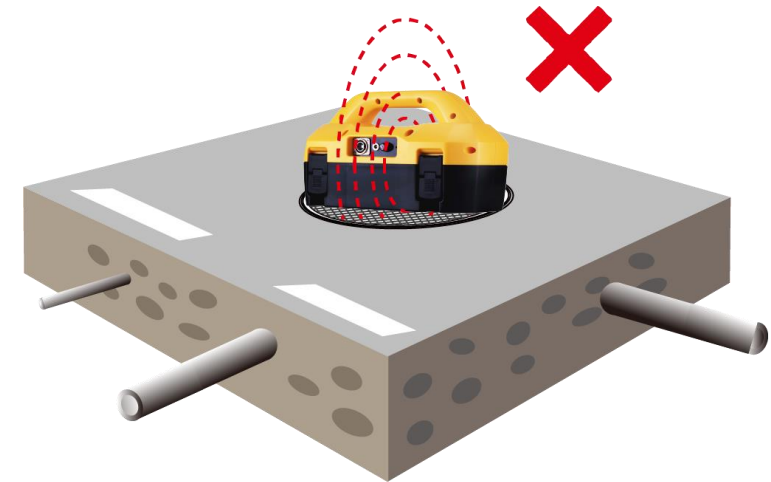

The accuracy of depth readings may be incorrect if taken closer than about 65ft (20M) to a transmitter on induction

## Active Sweep

- One other technique that can be undertaken with induction is an Active Sweep
- One person carries the transmitter in induction mode
- Another person 65ft (20m) away carries the receiver

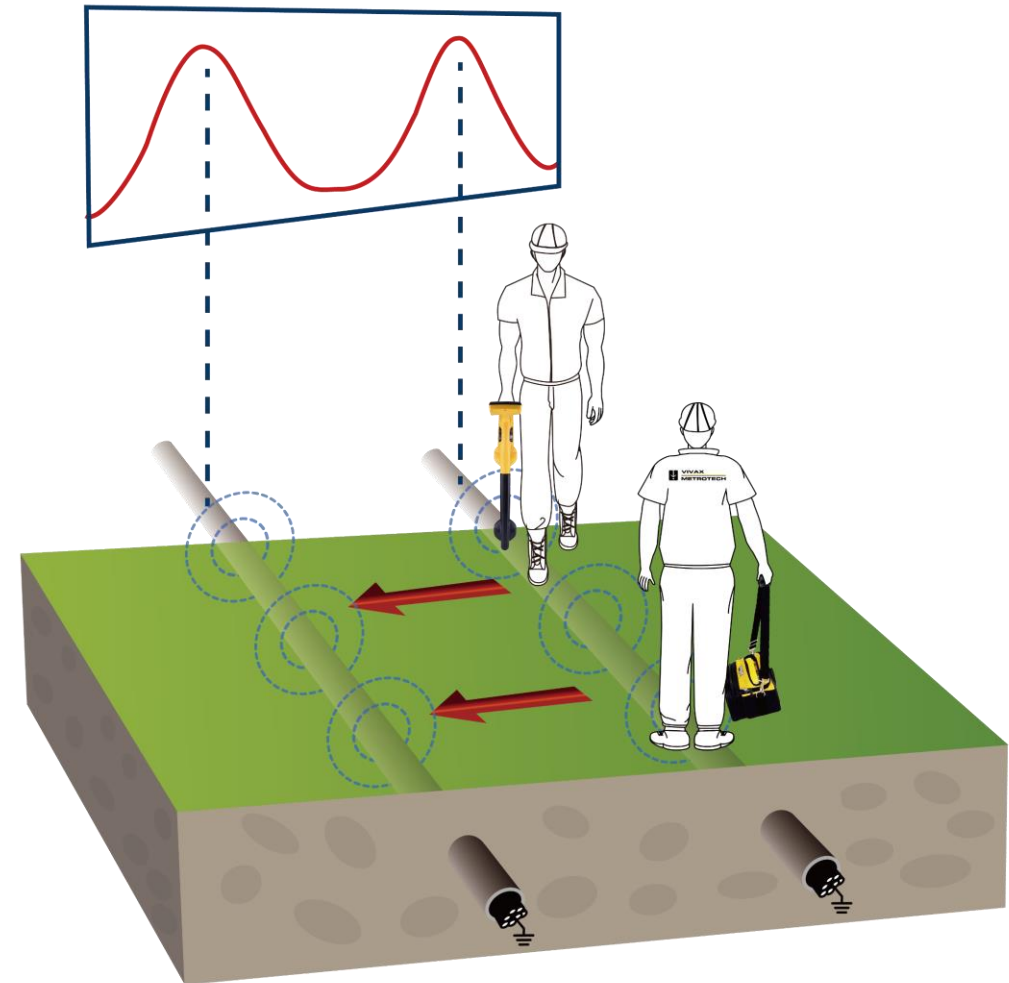

# Applying the Transmitter Signal – Frequency Selection



# Applying The Transmitter Signal – Frequency Selection

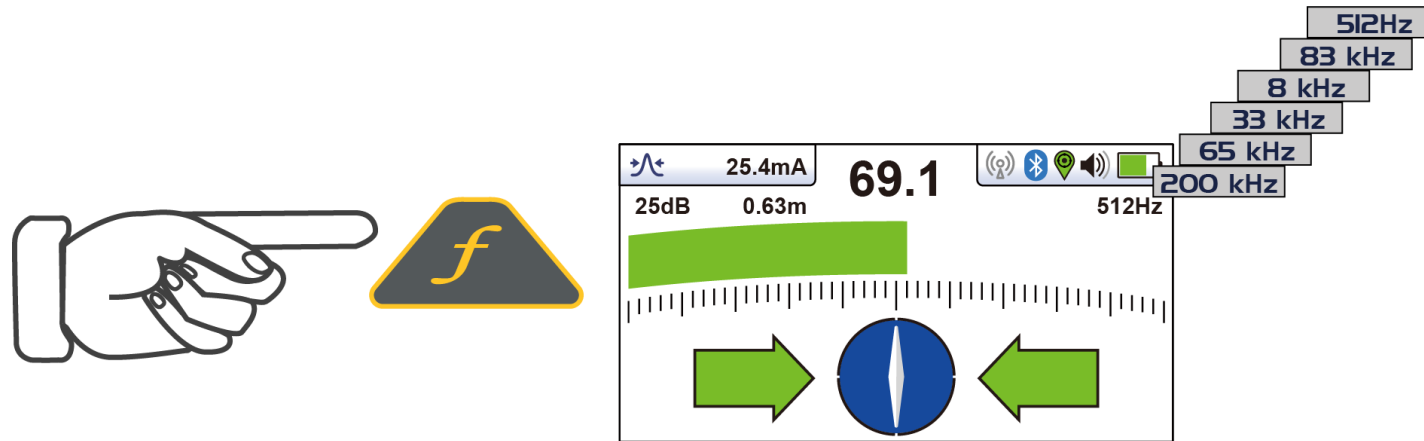

- Most transmitters have a selection of several different frequencies
- The best frequency for the job will vary depending on the way the signal is applied (direct connection, signal clamp or induction)
- Start low and work up till a frequency is found that is stable and strong
- The distance needed to complete the locate
- The type of Utility being located

## Low Frequency (100Hz – 1 kHz)

- Direct connection only
- Travels long distance
- Less coupling to adjacent lines
- Requires good grounds

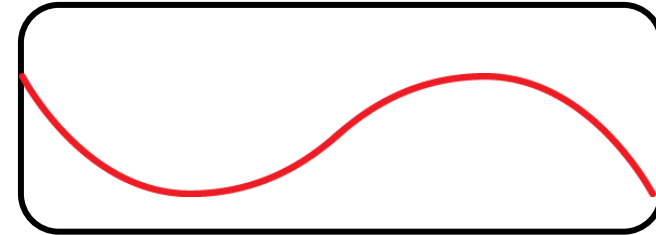

## Medium Frequency (8 kHz – 33 kHz)

- General purpose
- Cables and pipes
- Used by direct connection, clamp or induction
- Moderate distance
- Good all-around locating frequencies using any method of applying the signal

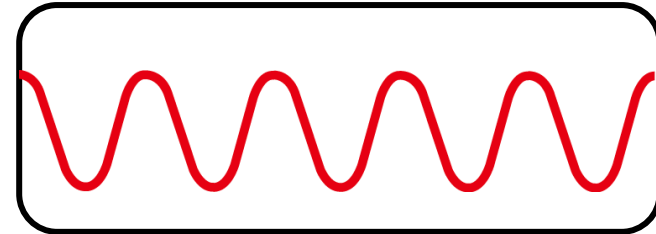

## High Frequency (65 kHz – 200 kHz)

- High resistance or poorly grounded
- Good for jumping insulated joints
- Most suited to induction
- Generally shorter distance
- Will couple to adjacent lines
- Good for induction, short distance and badly grounded lines

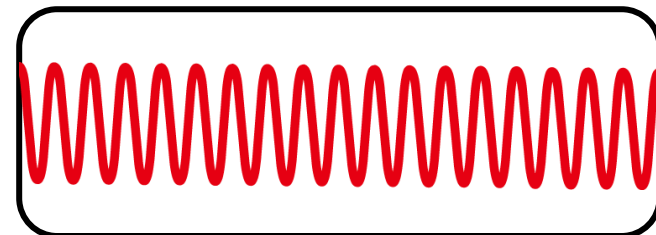

# Applying The Transmitter Signal – DFT

- Discrete Fourier Transform is a tool to help choose a frequency to apply to the target conductor.
- The DFT feature will aid the user with nearby interference that may affect the locate quality.

When using DFT, the receiver will scan all available frequencies while displaying a progress bar, and the list of frequencies assessed will be displayed.

A numerical value ranging from 0dB to 140dB will be presented next to the frequency list, with 140dB being the least possible interference detected and 0db with the largest possible interference.

The results are ranked from the least interference possible at the top to the largest amount of most possible interference at the bottom.

In this case, the higher the dB number (80dB), the less interference has been detected by the receiver.

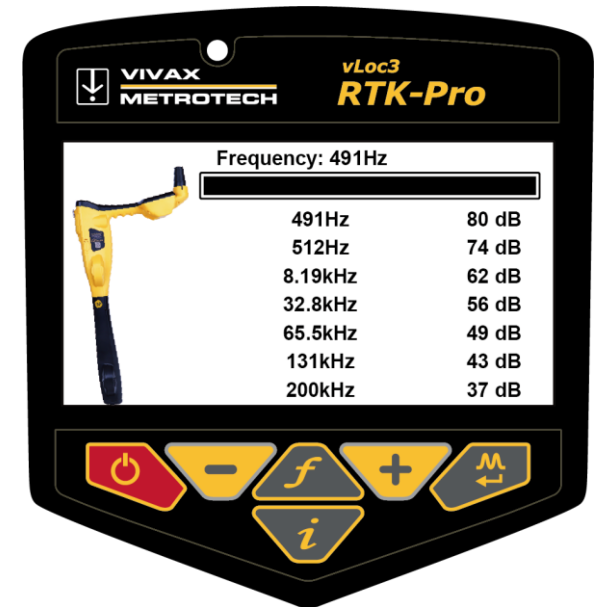

The DFT feature should not solely be used to determine which frequency to apply. ALWAYS follow the appropriate safety requirements mandated by safety legislation, safety practice, or your company's safety procedures when applying a locate frequency to a conductor.

# Receiver Locate Screens



# vLoc3-Pro Classic Locate Receiver Display

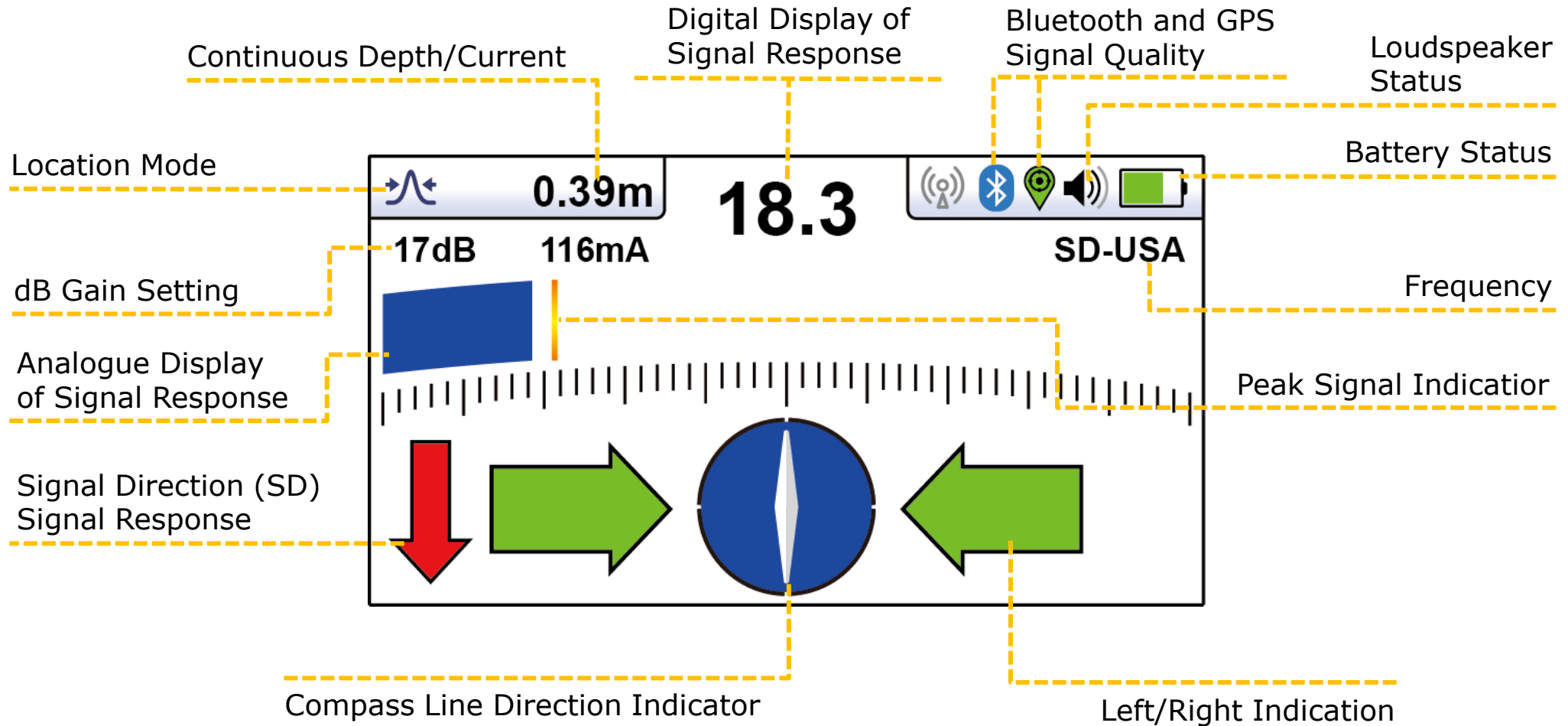

# vLoc3-Pro – Receiver Controls

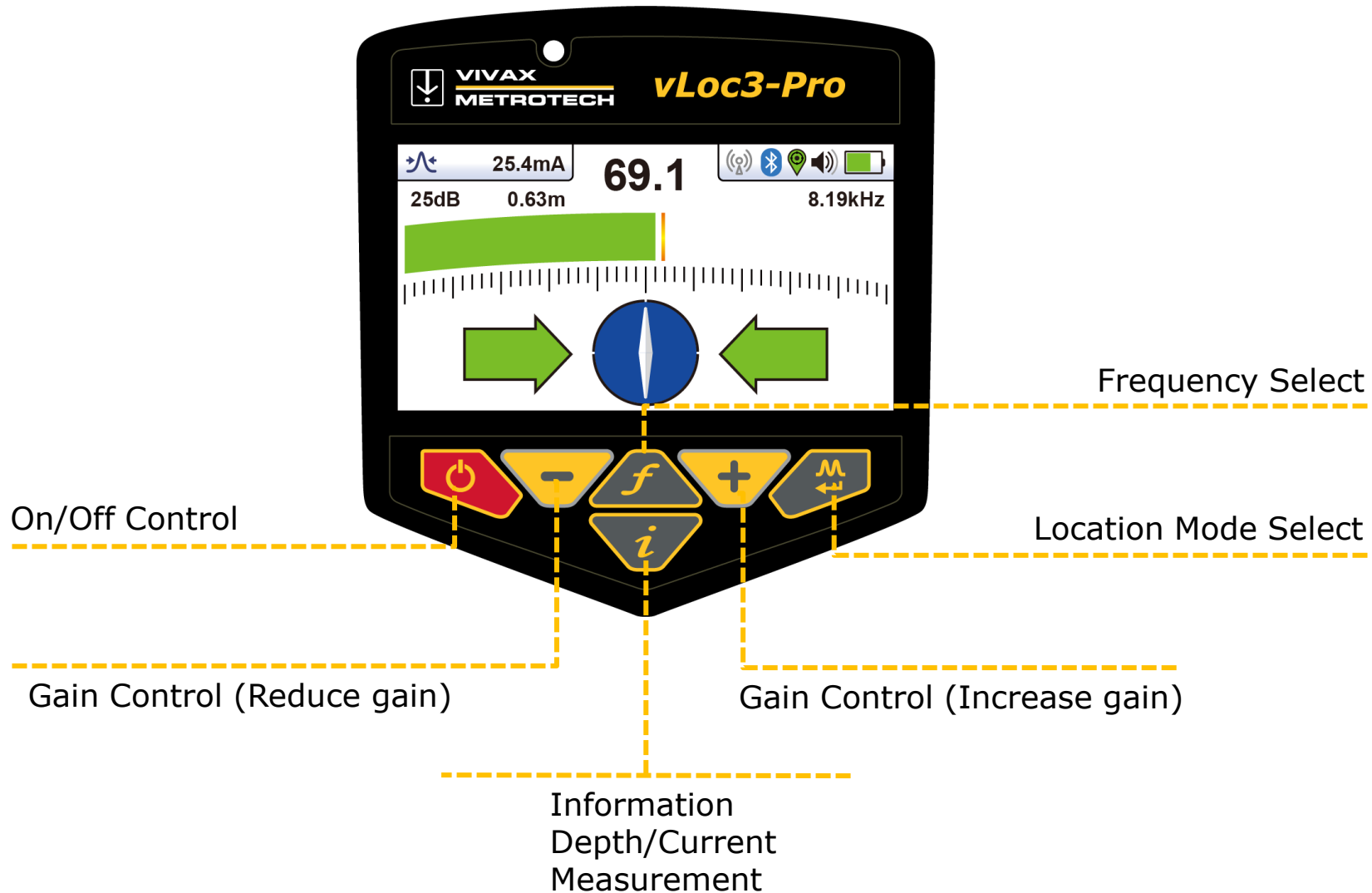

# Receiver Display - Warnings



Warnings can be displayed in real time across the display

## Signal Overload Warning



This is a very unusual situation and is usually caused by operating very close to a power transformer or placing the unit very close to a transmitter in the Induction mode. Moving slightly away from the interfering signal will cure the problem. Signal overload will not cause damage to the instrument.

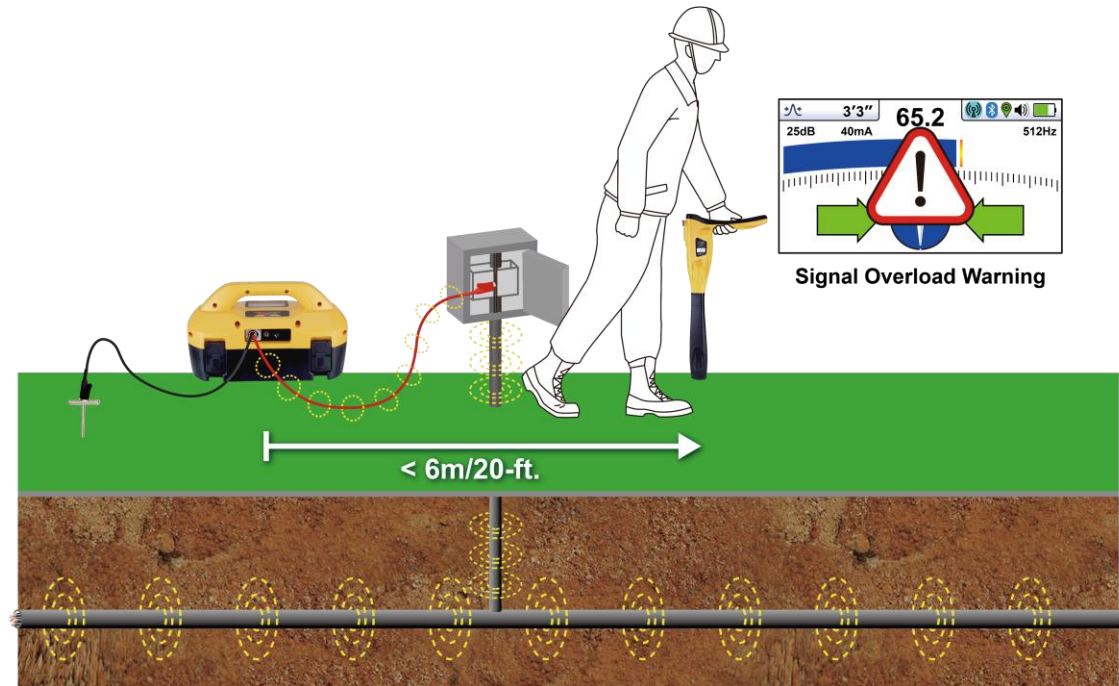



## Swing Alert



This indicates that the operator is swinging the locator excessively and could result in misleading information. When sweeping the locator across the direction of the line, try to keep it vertical. This will improve accuracy.

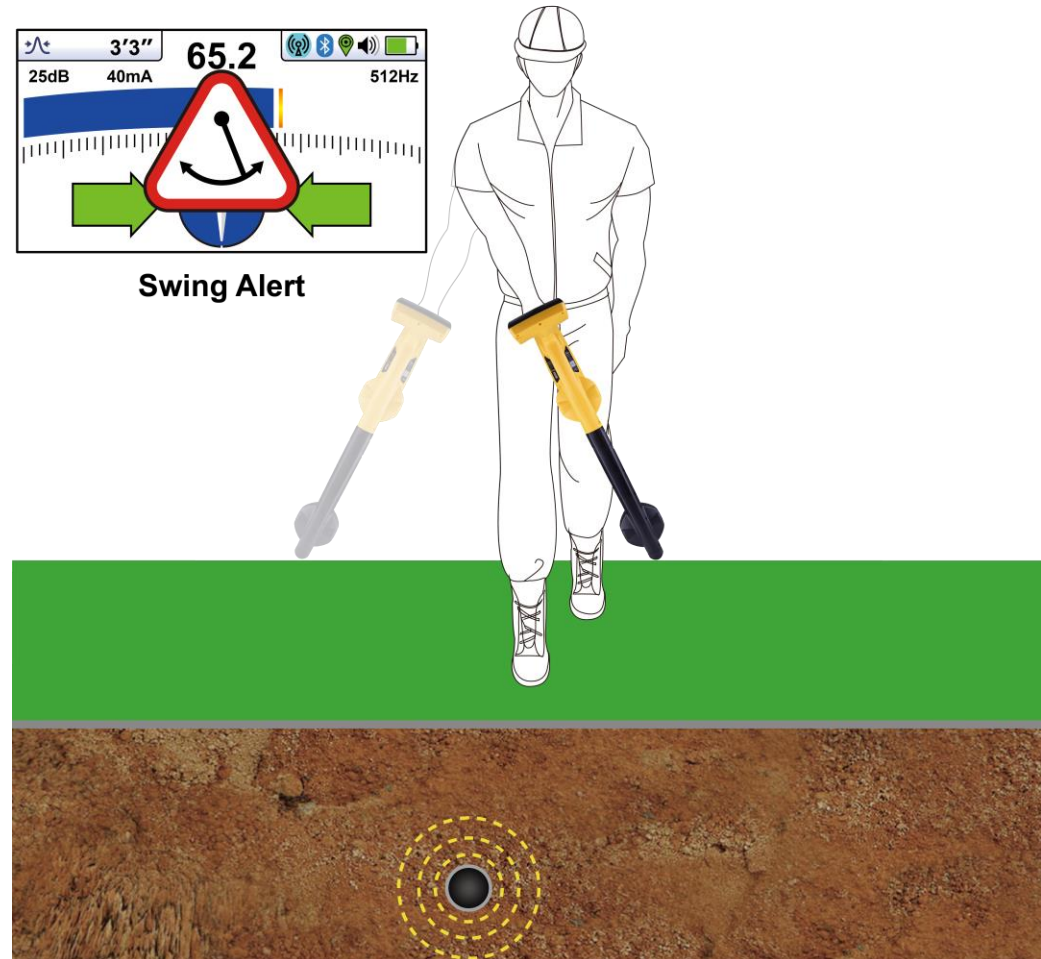

## Signal Overhead Warning



This indicates that the signal is mainly radiating from above. This is usually caused by the signal traveling along overhead cables.

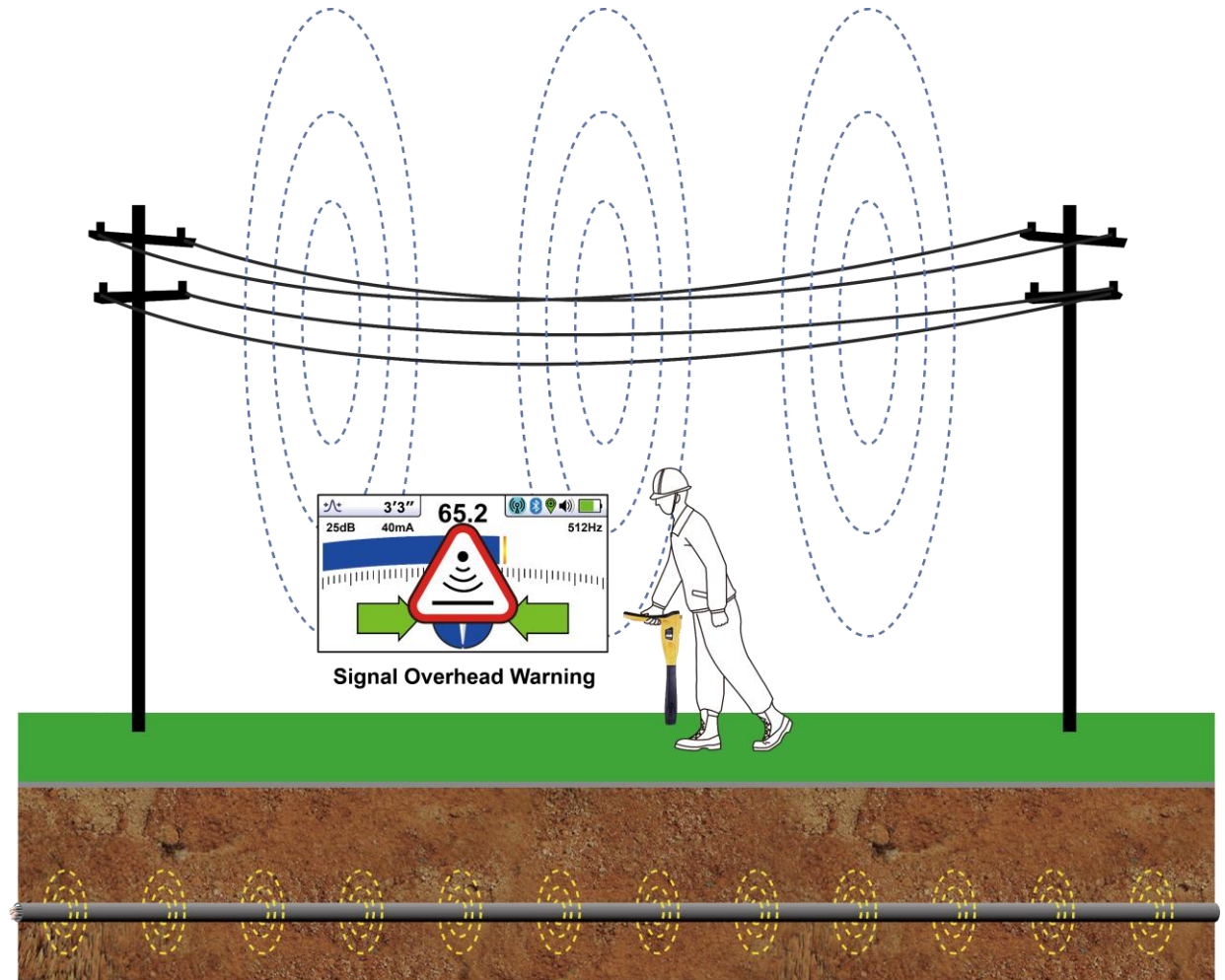

# Detecting the Locate Signal



- There are several antennas in a locator; these can be used in different combinations.
- Each combination, known as mode, provides different responses.
- The response types for general locating are Peak, Null, Left/Right distance sensitive and Omnidirectional. In this presentation, we will cover **Peak** and **Null**.
- Two additional modes are often used for specific applications
  - **Broad Peak** - useful when locating very deep lines-operates like peak mode.
  - **Sonde Mode** - for locating Sondes or CCTV inspection cameras (see Sonde section).









# Locating Modes



# Receiver – Operating Modes

Select the locating mode:

	<b>Peak with Arrows</b> – Similar as the Peak mode but with Left/Right arrows
	<b>Peak Mode</b> – Best for tracing and pinpoint the line in congested areas
	<b>Broad Peak Mode</b> – Best for tracing and pinpoint deep lines
	<b>Null Mode</b> – Best for verifying the peak locate
	<b>Delta Null Mode</b> – Similar to Null with a sharper response
	<b>Omni Directional Peak</b> – Can be used regardless of the locator blade orientation

# Modes – Peak with Arrows

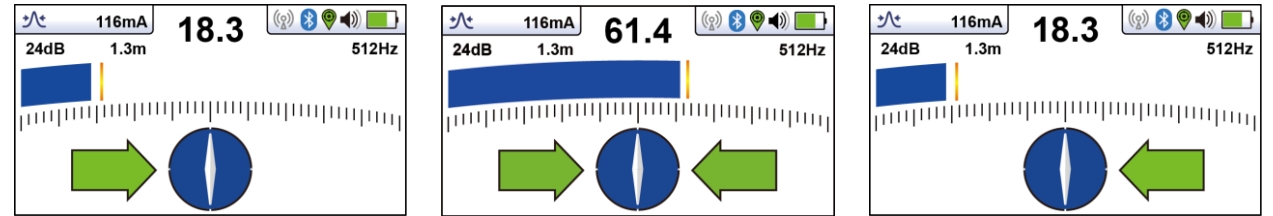

## Peak with Arrows mode

- Provides a maximum response over the line
- Uses two peak antennas
- Left/Right arrows are displayed

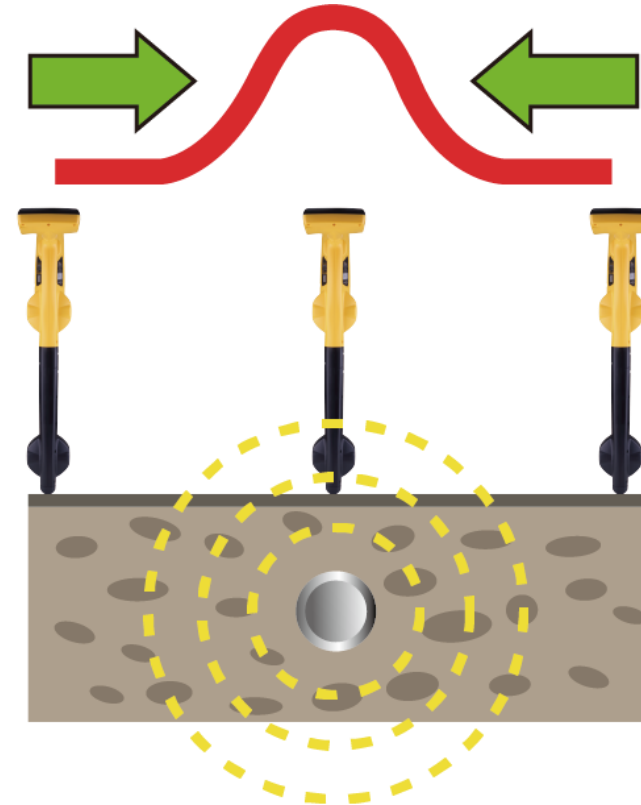

# Modes - Peak

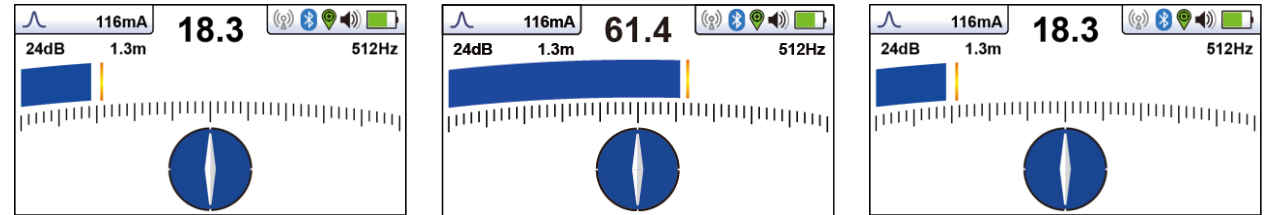

## Peak mode

- Provides a maximum response over the line
- Uses two peak antennas
- The most accurate locate mode

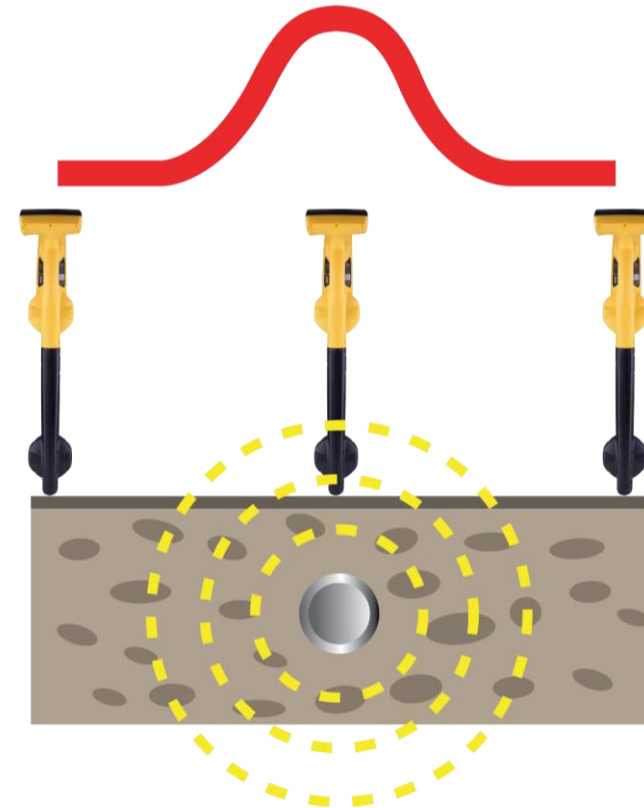

# Modes – Broad Peak

## Broad Peak

- Provides a maximum response over the line
- Uses a single peak antenna
- Provides increased sensitivity for deep utilities
- The response is broader, so it may be difficult to Pin-Point

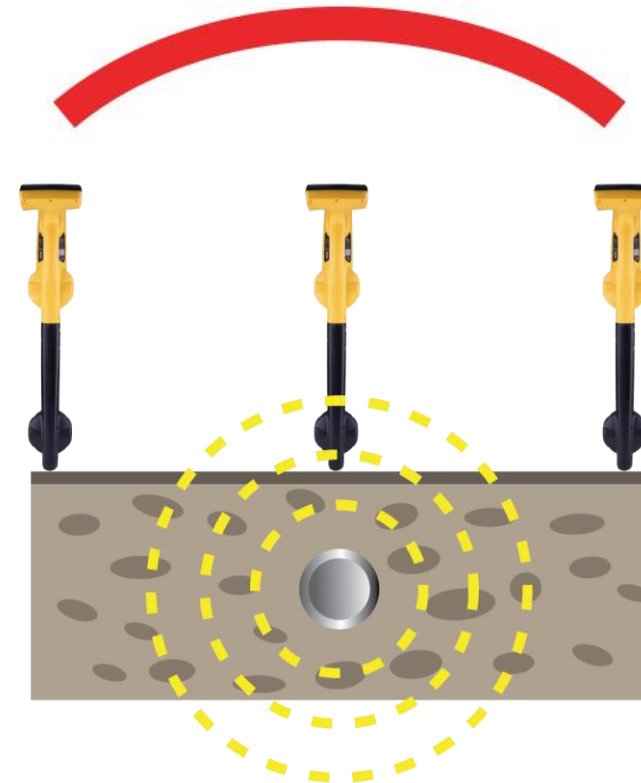
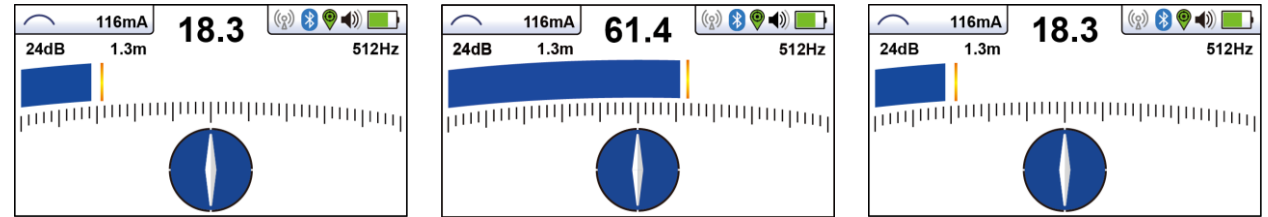

# Modes - Null

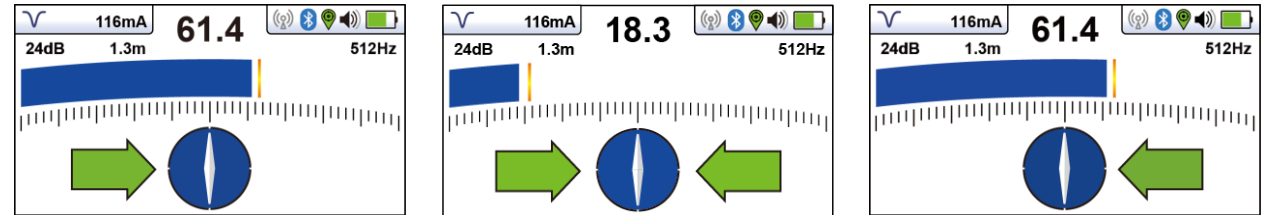

## Null mode

- Provides a minimum response over the line
- Uses the single vertical bottom antenna
- Shows left/right arrows
- Is used to compare the position of the Peak locate

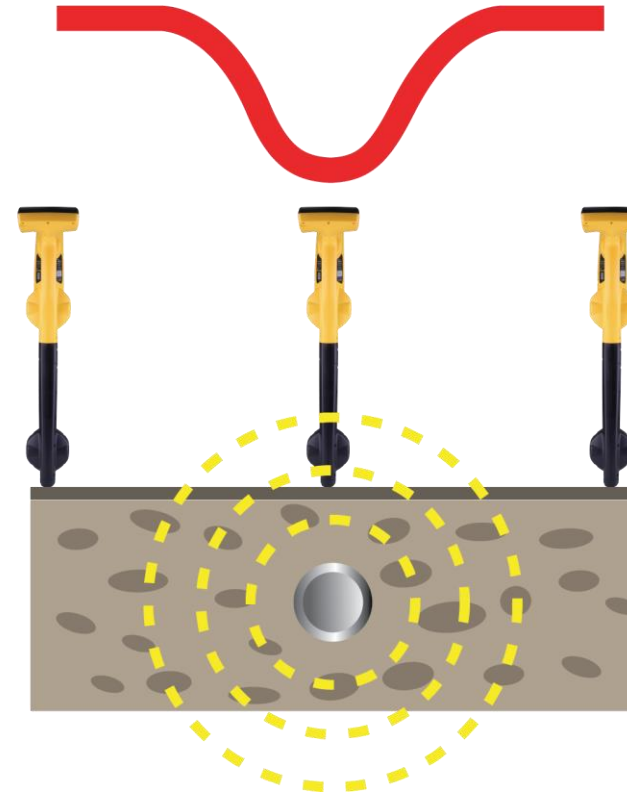

# Modes – Delta Null

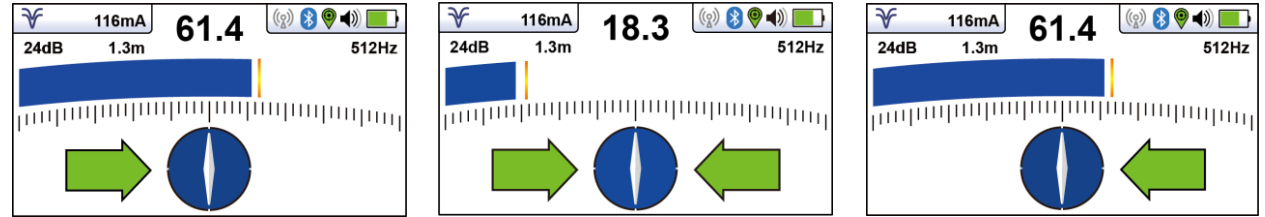

## Delta Null mode

- Provides a minimum response over the line
- Uses top and bottom vertical antennas
- Used to compare the position of the Peak locate

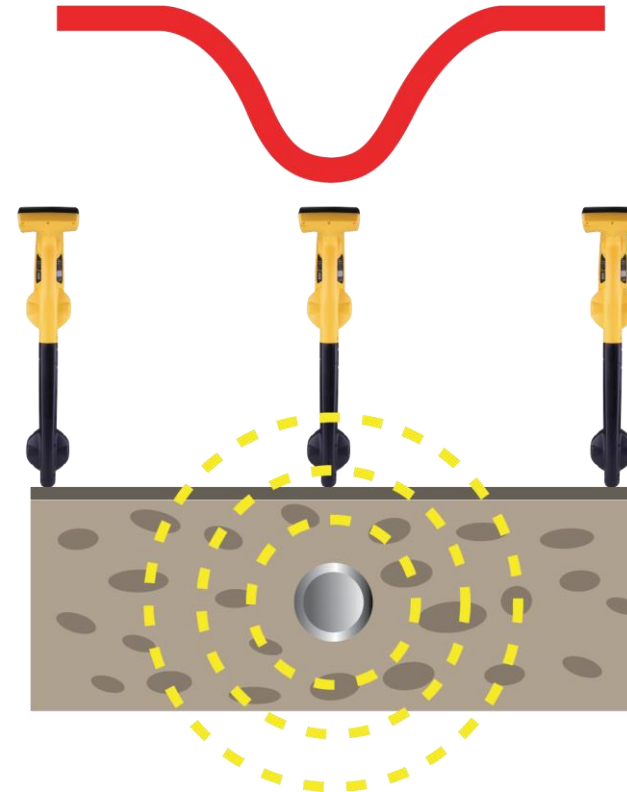

# Modes – Omni Directional Peak

## Omni Directional Peak mode

- Uses twin peak and null antennas
- Provides a minimum response over the line
- Can be used regardless of the locator blade orientation

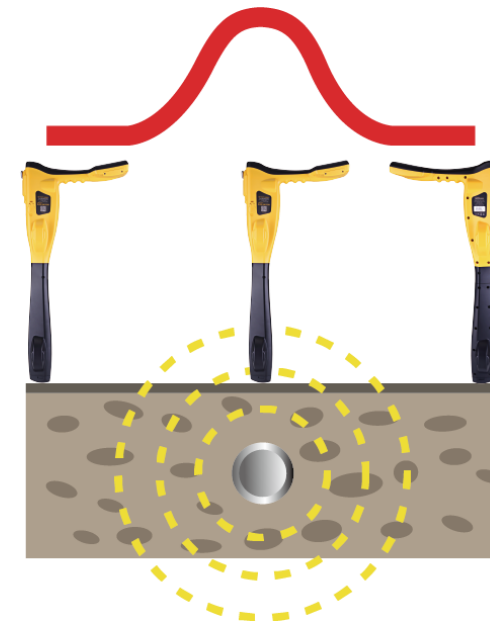
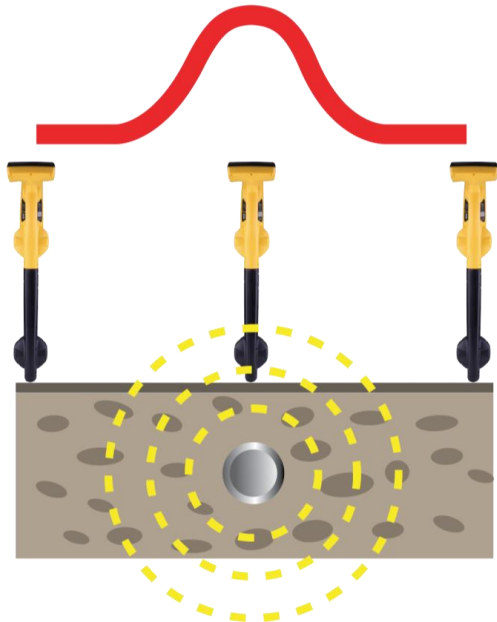
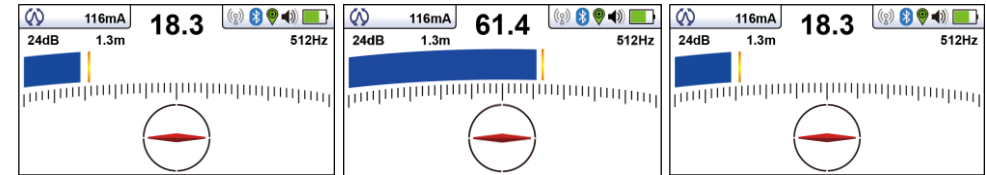
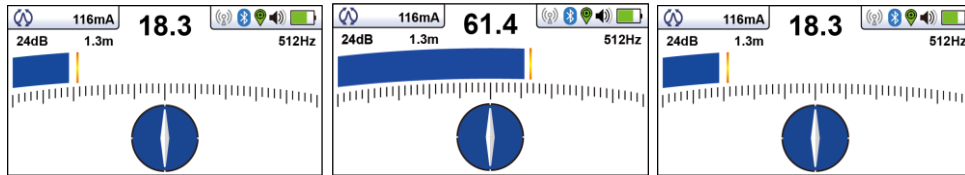

# Compass Feature

## Compass

- Provides the direction and orientation of the line

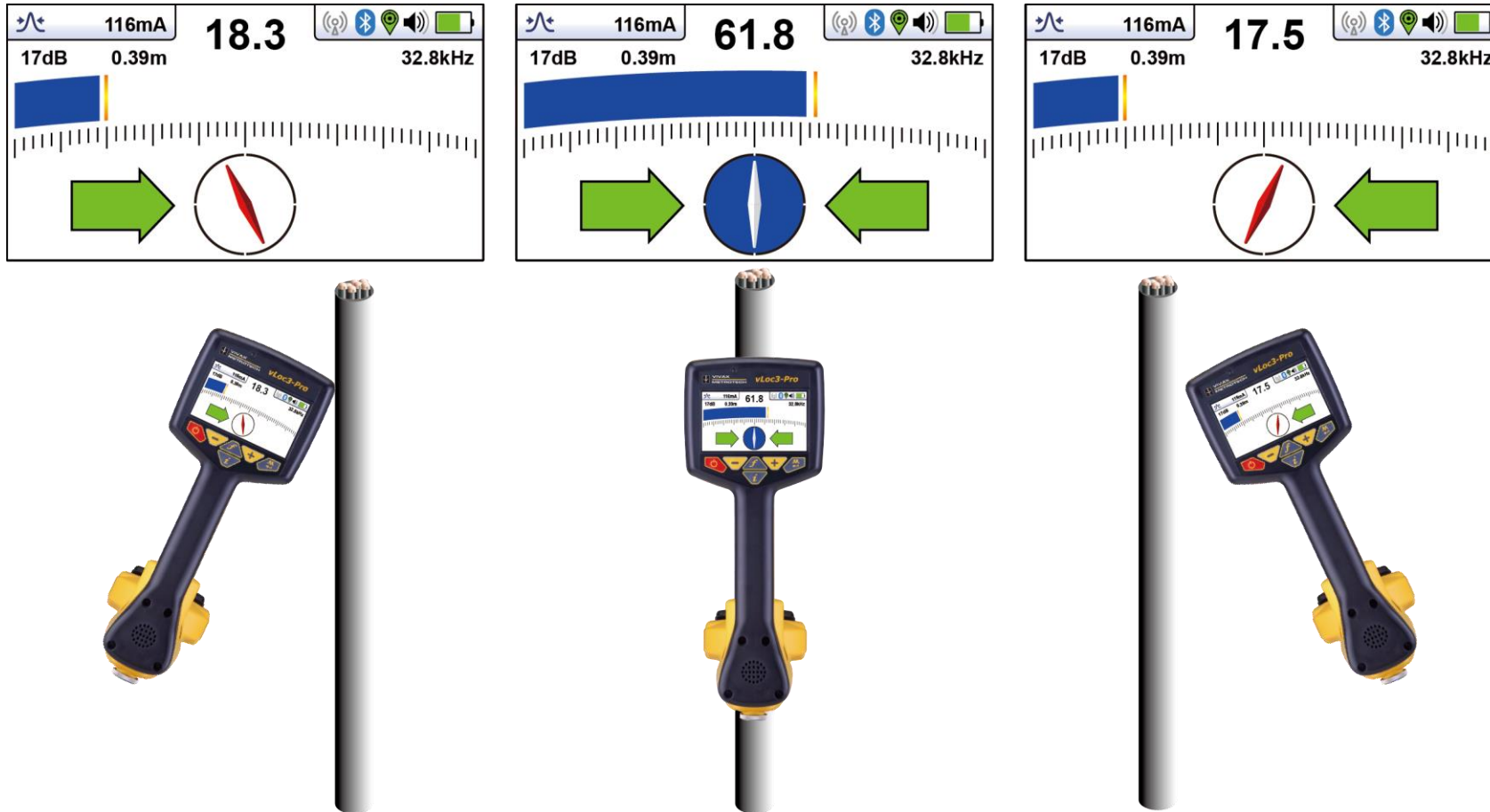

# Distorted Fields



# Distorted Fields

The magnetic field (the signal) radiating from buried lines can be distorted by the presence of adjacent metallic conductors, objects or other signals.

This is caused by:

- Signals induced from the target line to other lines
- Commonly bonded structures
- Badly positioned ground (at the transmitter)
- Large metallic objects above or below the surface

The result is that the locator detects signals from more than one source

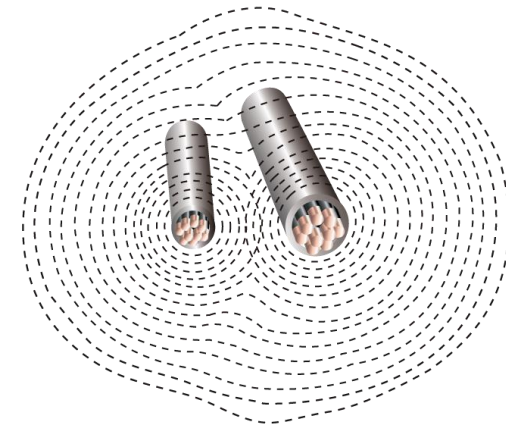

**A typical distorted field**

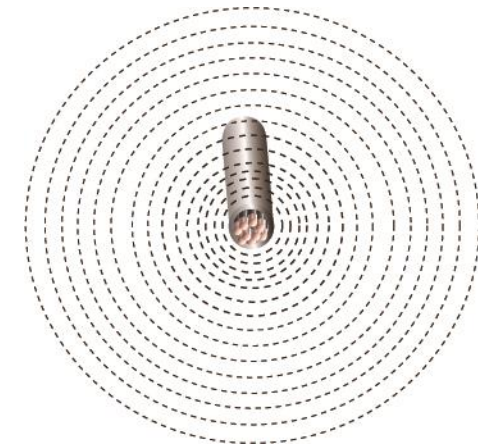

**A clean undistorted field**

# No Distortion



# Low Level of Distortion



# High Level of Distortion



# Identifying Distorted Fields

Use **Peak with Arrows** mode to identify distorted fields

- On a clean, undistorted field, the Peak and Null locate response will line up
- If distortion is present, the peak and null locate response will not line up

Typically, the greater the distortion, the further apart these located responses are.

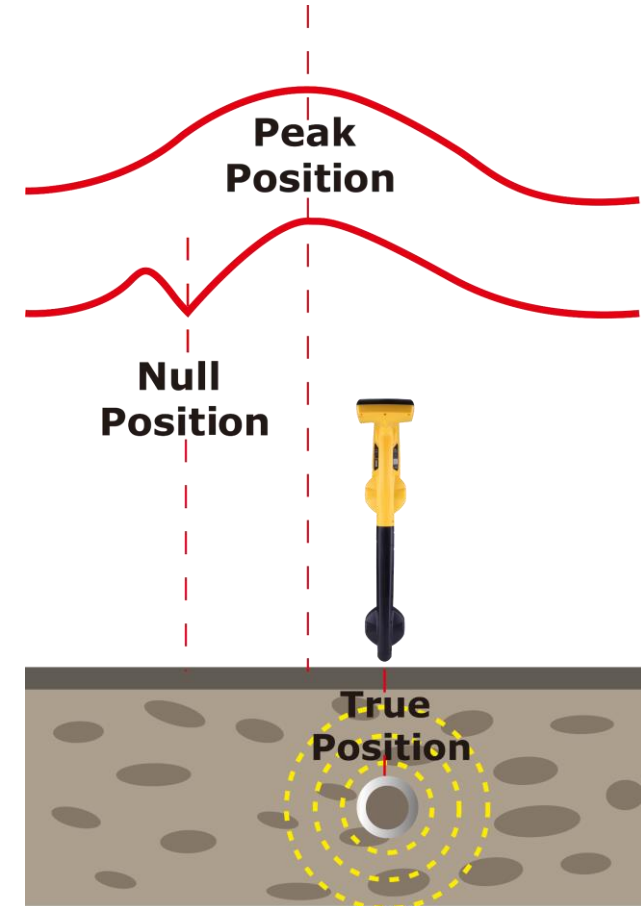

# Identifying Distorted Fields

Using Depth Measurement to identify a vertical distorted field

- Locate the line & measure depth with the locator resting on the ground
- Lift the receiver off the ground by a known distance (say) 1ft (30cm)
- Take another depth reading

The depth reading should have increased by the distance you raised the receiver. **If it is significantly different**, the field is distorted.

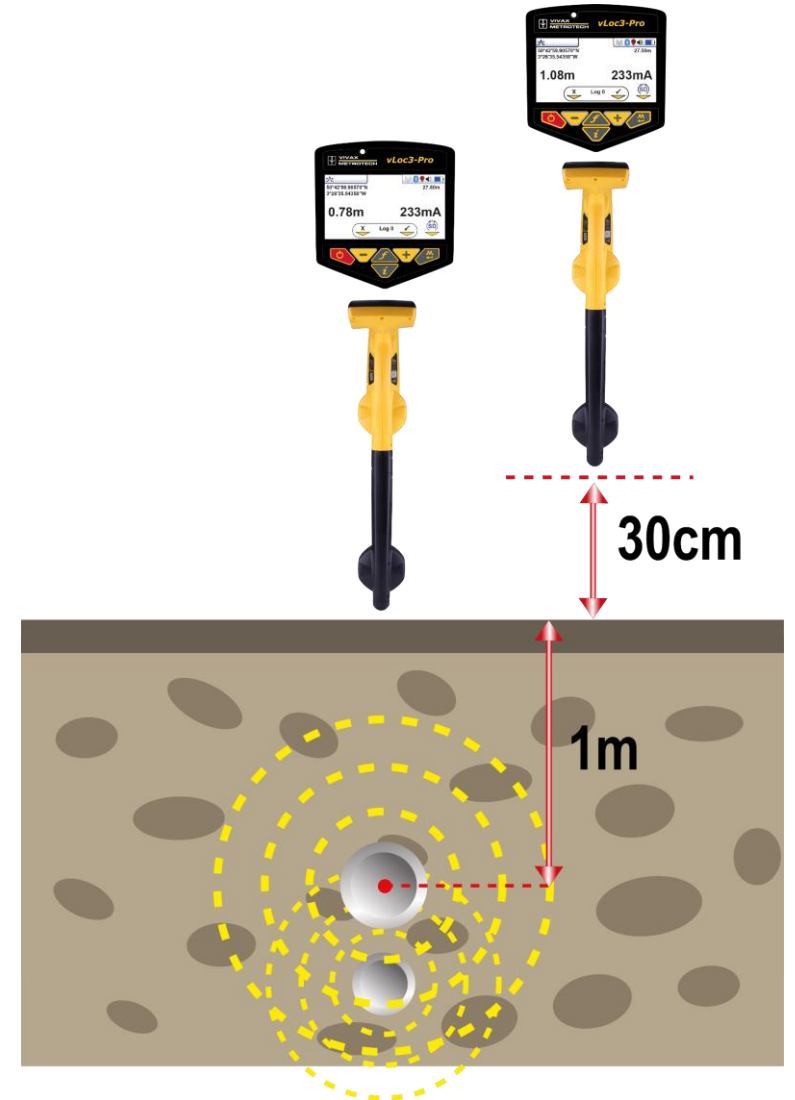

# Measuring Depth and Current



# Measuring Depth

- Depth can be measured using a locator
- Depth is measured to the center of the signal – in the case of large diameter pipes, this can be closer to the top of the pipe
- Some locators provide continuous depth and current on screen – this is only accurate when directly over top of the line

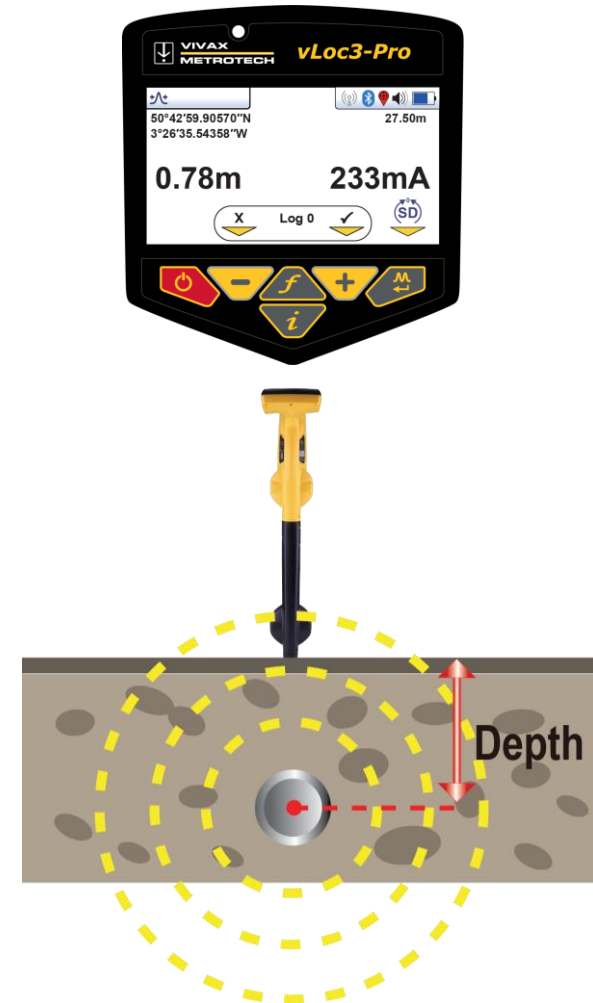

# Measuring Depth

## How to measure Depth:

- Locate the line & measure depth with the locator resting on the ground
- Lift the receiver off the ground by a known distance (say) 1ft (30cm)
- Take another depth reading

The depth reading should have increased by the distance you raised the receiver. **If it is significantly different**, the field is distorted and should not be trusted.

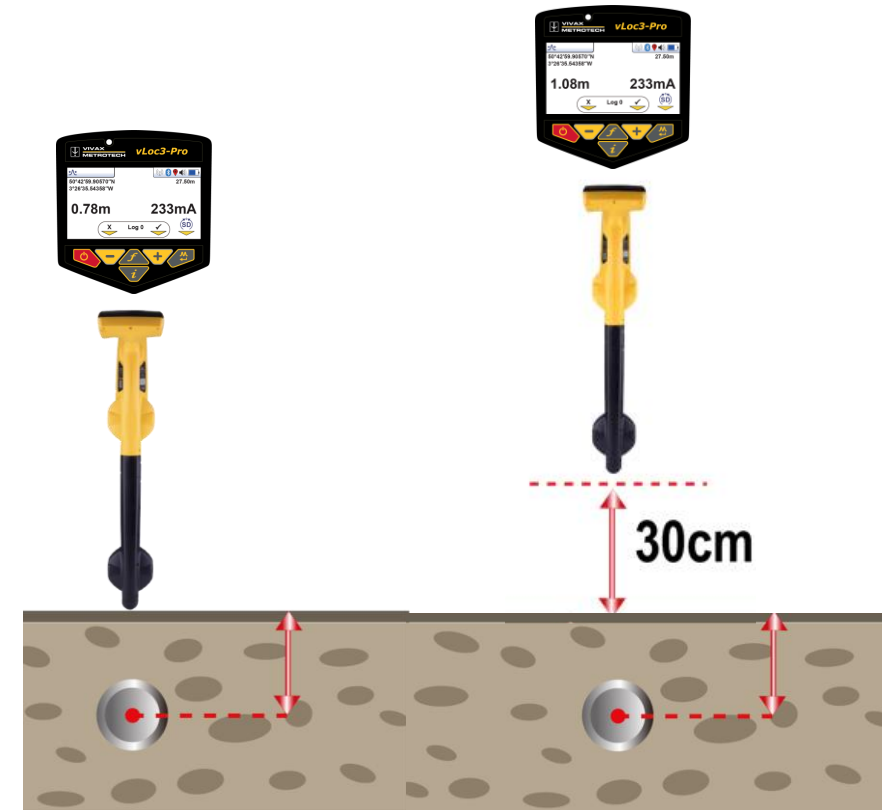

# Measuring Depth and Current

**Do not** rely on depth and current measurements made if...

- Close to bends in the line
- Close to a "T" in the line
- Close to the transmitter
- Where the line is changing depth
- Where the field distortion has been identified

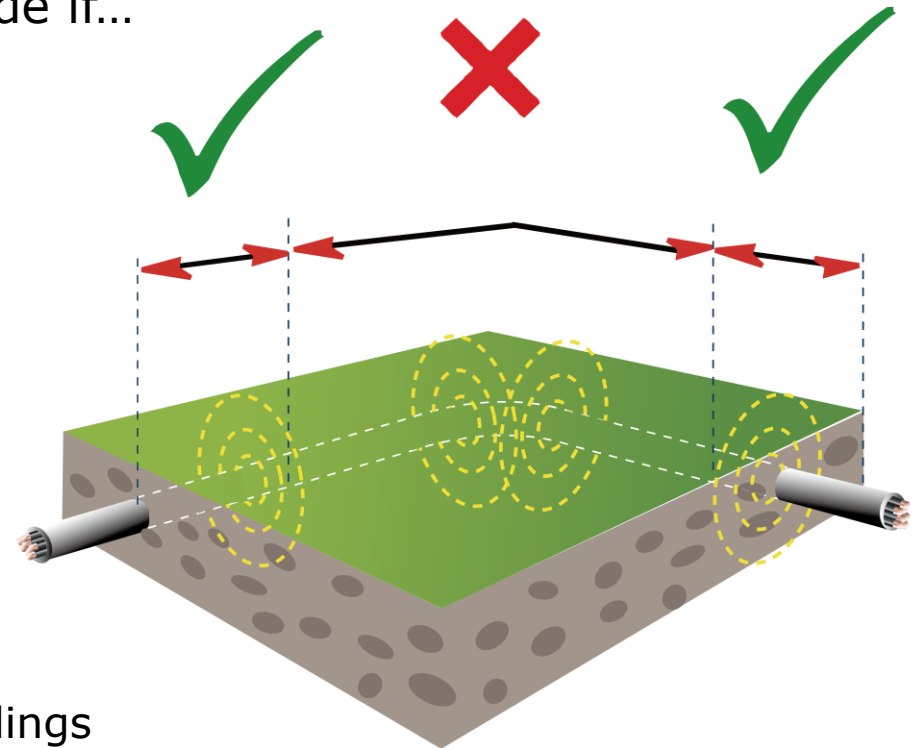

All these factors can result in inaccurate depth readings

# Measuring Depth and Current

To take a depth & current measurement, first pinpoint the line

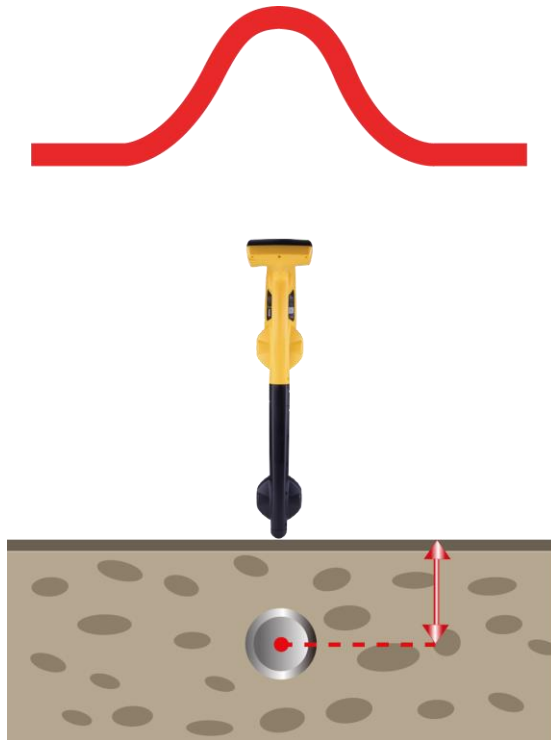

The depth and current readings are continuously displayed on the receiver.



# Using Signal Current to Help Identify The Target Line

- Current reading should closely match what is being put out by the transmitter.
- Current readings are **not** influenced by depth.
- Current readings should **not be higher** than the current being transmitted.
- Current readings should reduce gradually unless
  - There is a "Tee" in the line
  - A significant fault in the insulation
  - You are on the **wrong line!**

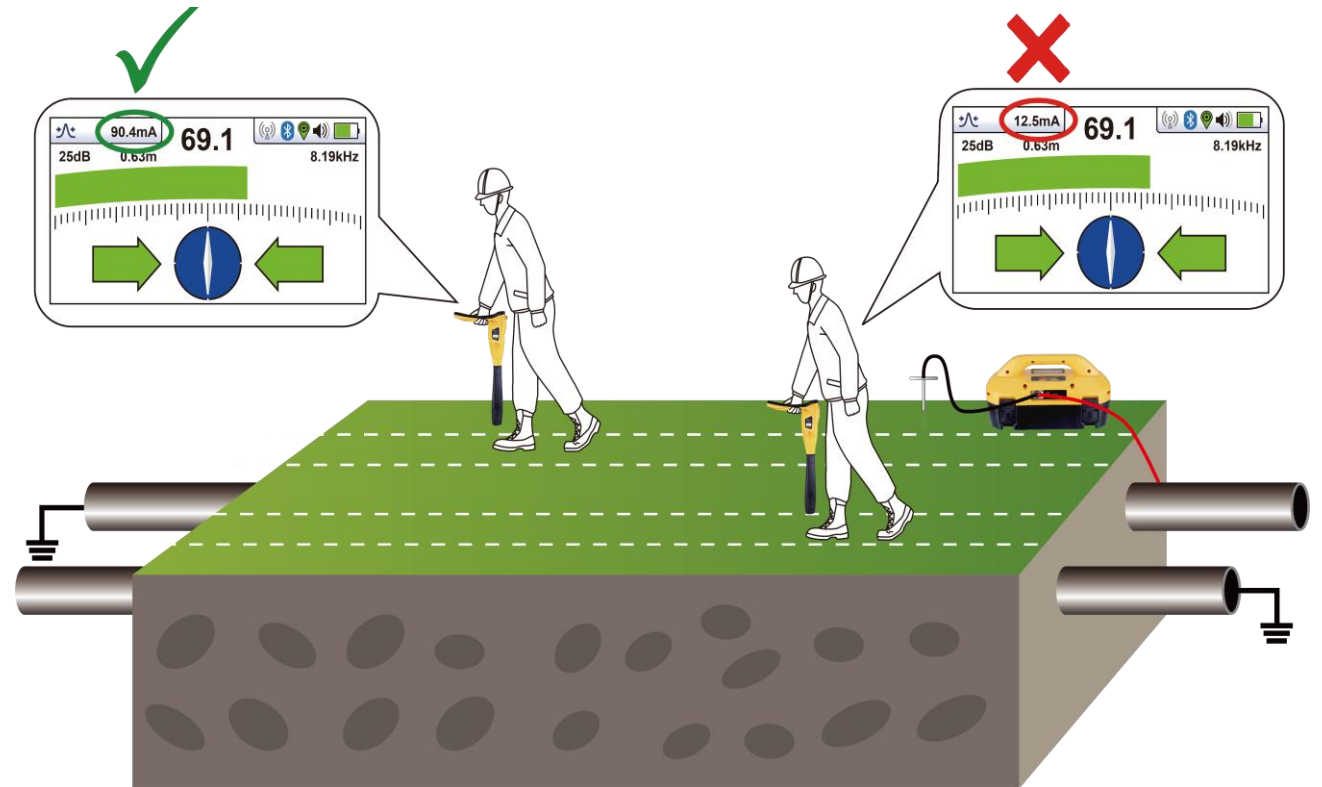

# Locating Sondes



# Locating Sondes

- Sondes are small alkaline battery-powered transmitters commonly used to trace metallic and non-metallic pipes, ducts and conduits.
- Sondes radiate a signal with a different shape to the signals emitted from cables.
- Because the signal radiates differently, a specific Sonde mode is used on the receiver.
- Sondes are available in multiple frequencies and sizes, which correspond to their size.

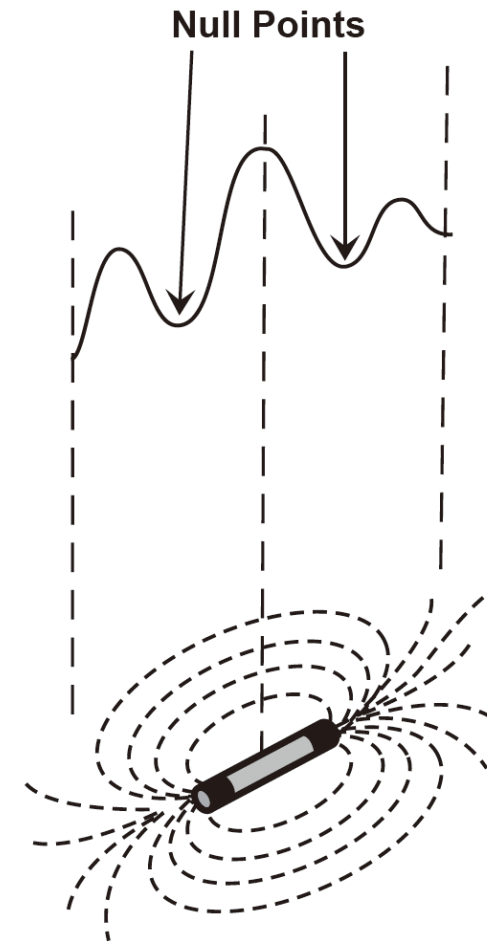

# Locating Sondes

- The Sonde signal gives three peaks in line with the path of the sonde. A larger middle peak and two smaller peaks, referred to as Ghosts, are ahead and behind the Sonde

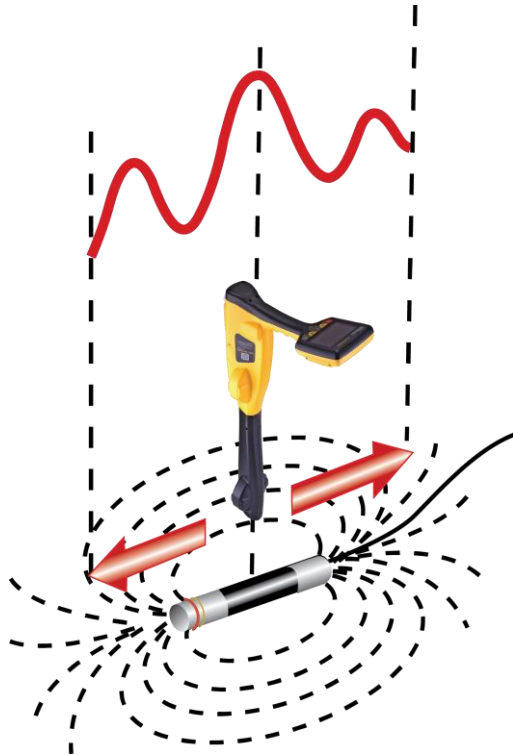

- A single peak can be found when moving across the line of the Sonde.

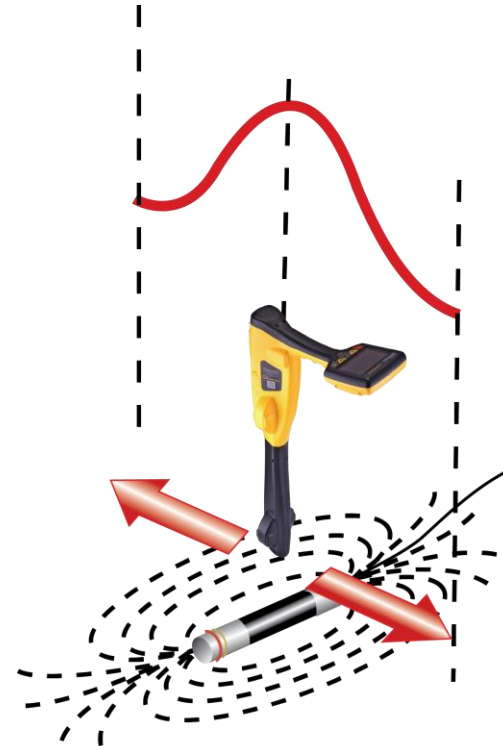

# Locating Sondes

A good sonde locator will clearly point out which is a ghost signal or a true peak signal.

The below illustration shows how this sonde locator interprets and shows the Null points as blue circles and the sonde by a two-color sonde icon.

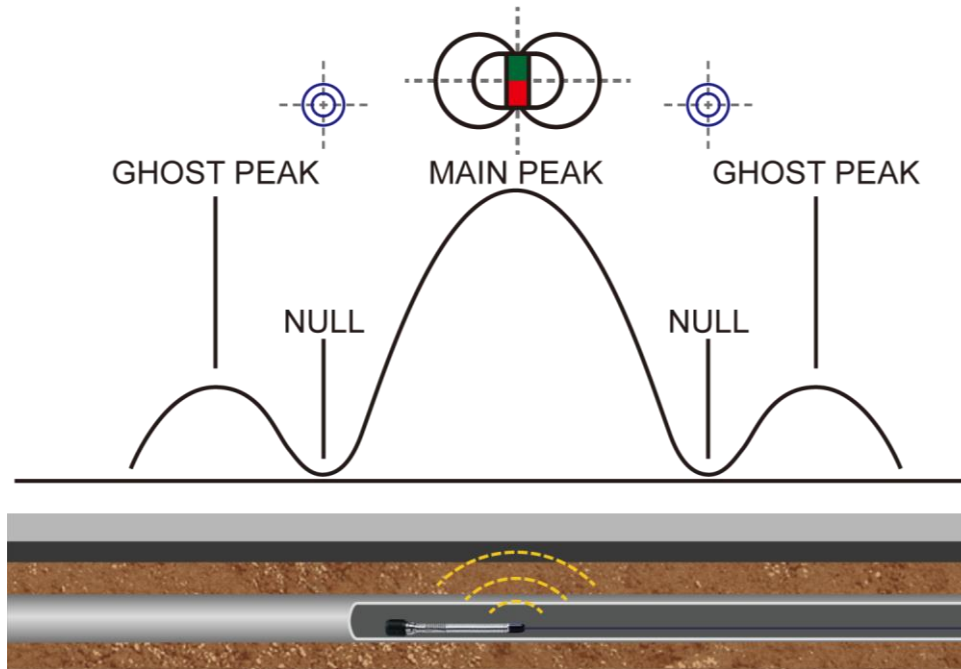

Actual signals

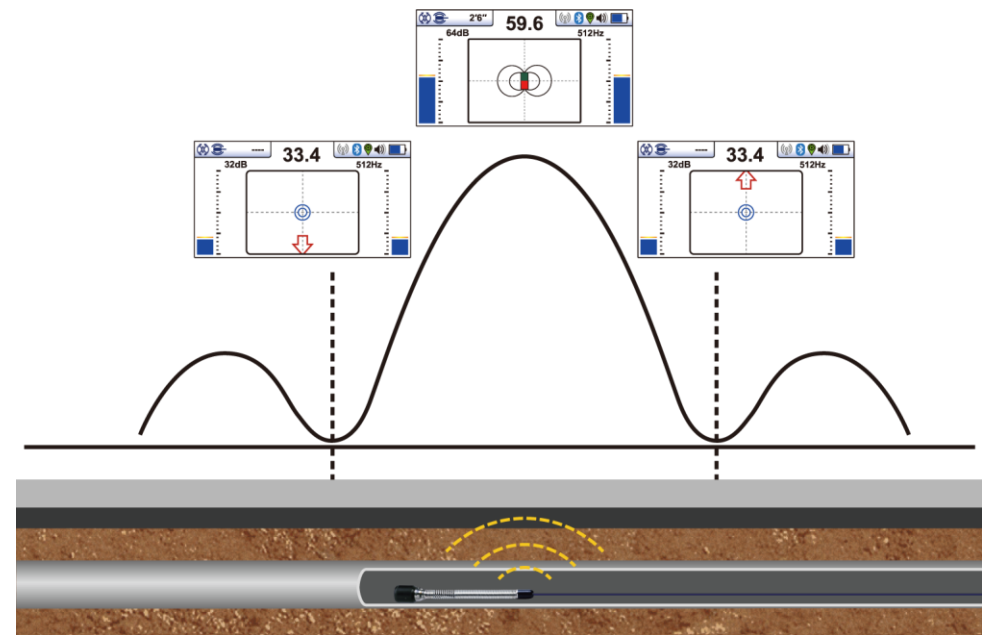

Receiver display

# Locating Sondes

Push the activated sonde into the pipe.

Walk slowly in the direction of the arrow on the screen. A double circle will appear first on the screen. This indicates the position of the Ghost signal. Position it in the crosshairs of the screen.

Continue walking in the direction of the arrow, towards the center of the sonde.

A Green and Red sonde icon will soon appear. When the Sonde Icon is in the center of the crosshairs, the locator is now directly over the sonde.

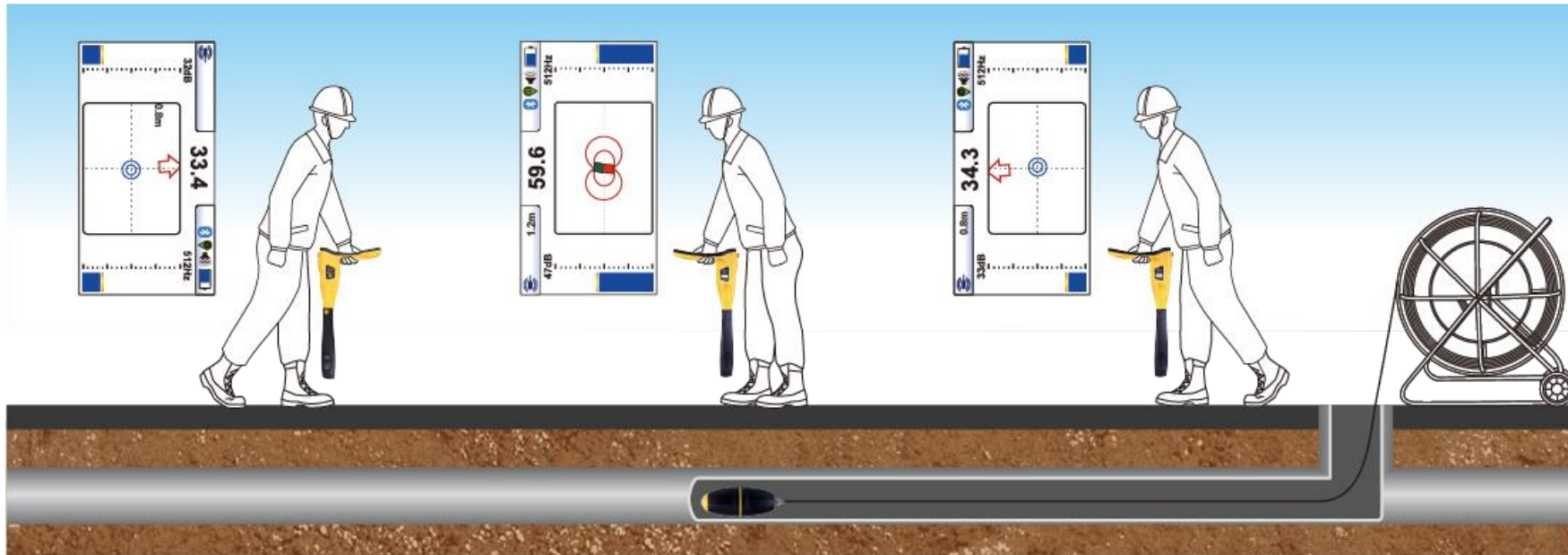

# Signal Direction



# Signal Direction (SD)



Signal Direction, SD Mode, is used to help verify if the line being located is the line that the transmitter has been connected.

When a transmitter is connected to a target line, the signal travels along it and finds the easiest way to travel back, usually via the ground and ground stake. However, the signal will often travel back along adjacent cables or pipes as these can offer an easier route.

As a result, multiple signals can radiate from cables and pipes in the area, making it challenging to identify the target line. These return signals typically travel in the opposite direction than the applied signal. The Signal Direction feature can help identify which direction the signal is flowing and provide an additional level of confirmation while locating.

# Signal Direction (SD) – Transmitter Setup

- Turn the transmitter and receiver on and set both to :
  - SD-USA – if in North America or any territory where the power system is 60Hz.
  - SD-EUR – if in Europe or any territory where the power system is 50Hz.
- The receiver may or may not be flashing the “SD” icon and showing an arrow on the screen.

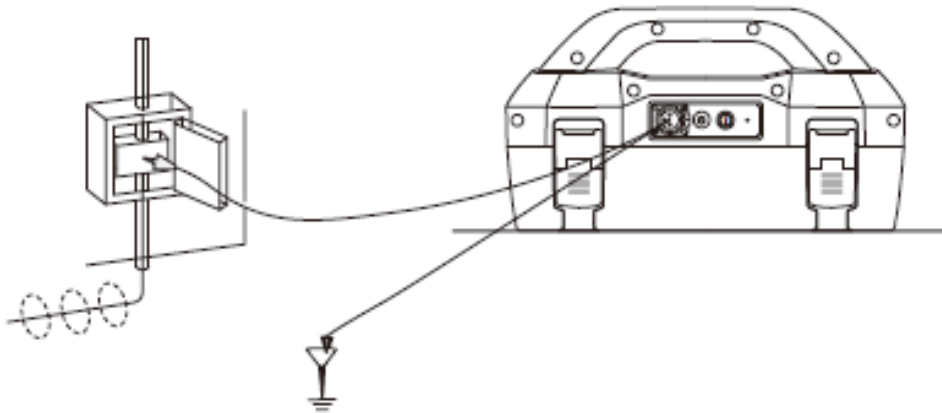

# Signal Direction (SD) - Synchronize

- To synchronize the receiver to the transmitter at the beginning of a survey, pinpoint the line very close to the transmitter.
  - Stand facing away from where the transmitter is attached and press the “I” pushbutton.
  - Press the return or “m” button to synchronize the system, then return the unit to the locate screen.
  - The Arrow should show on screen pointing forward, indicating the receiver is locked onto the signal.

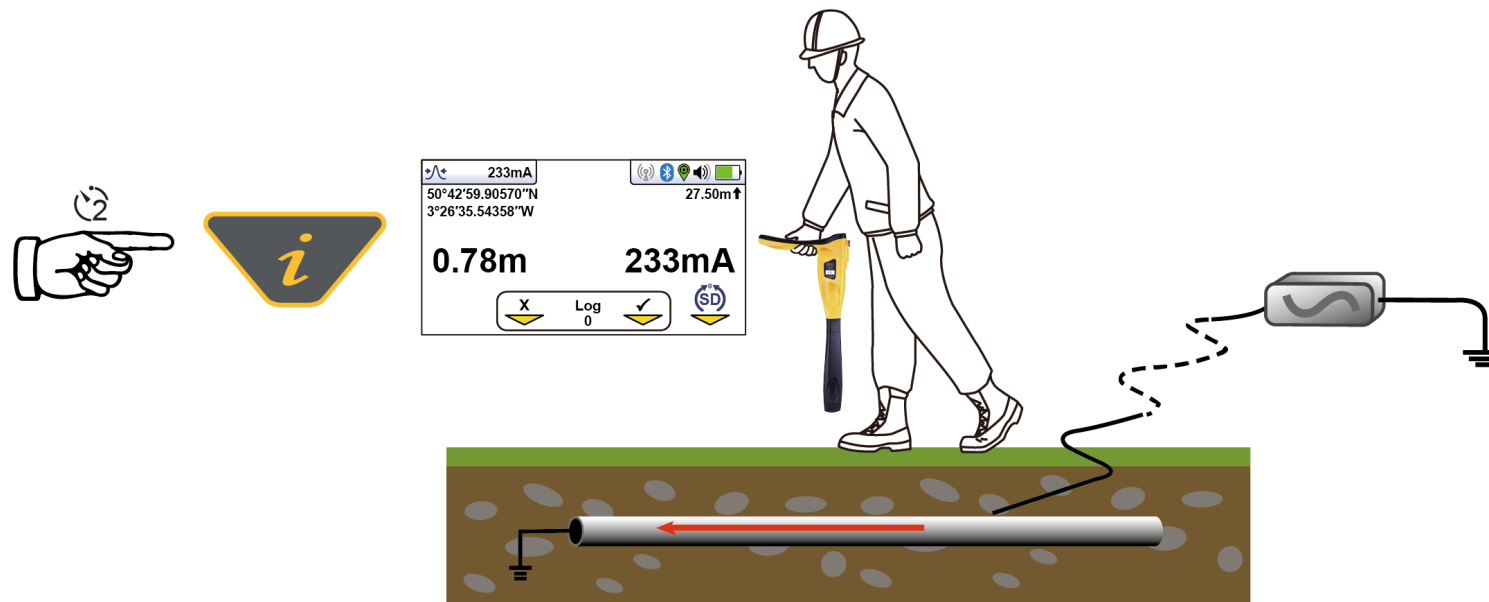

# Signal Direction (SD) - Using

- Proceed to locate, trace, and pinpoint as required, ensuring that the Arrow remains pointing away from the transmitter.
- If at any time the Arrow flips around and is red, you are possibly locating the wrong line which may be carrying the return signal.

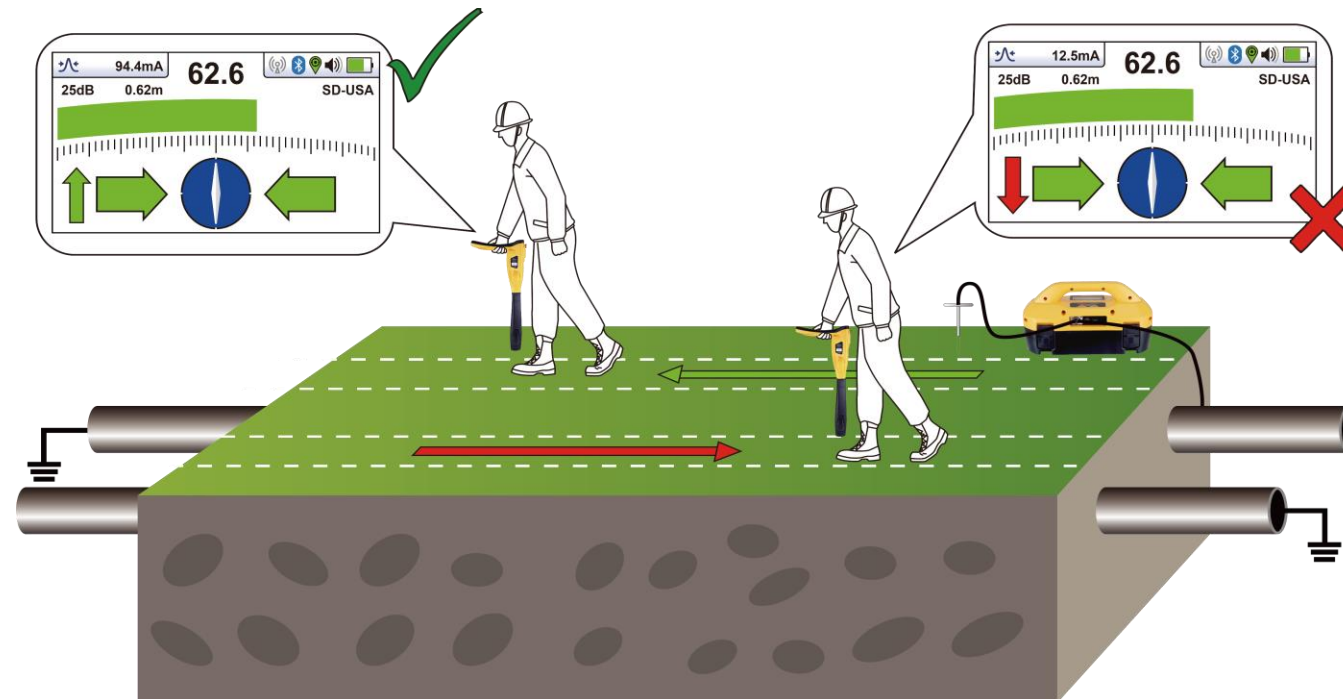

# Signal Direction (SD) - Using

Re-trace your line back to a point where a solid signal direction, forward green arrow, is obtained.

- Precisely pinpoint the line and stand with your back to the direction of the transmitter
- Press the " i " pushbutton
- Press the enter "m" button to re-sync with the transmitter signal.

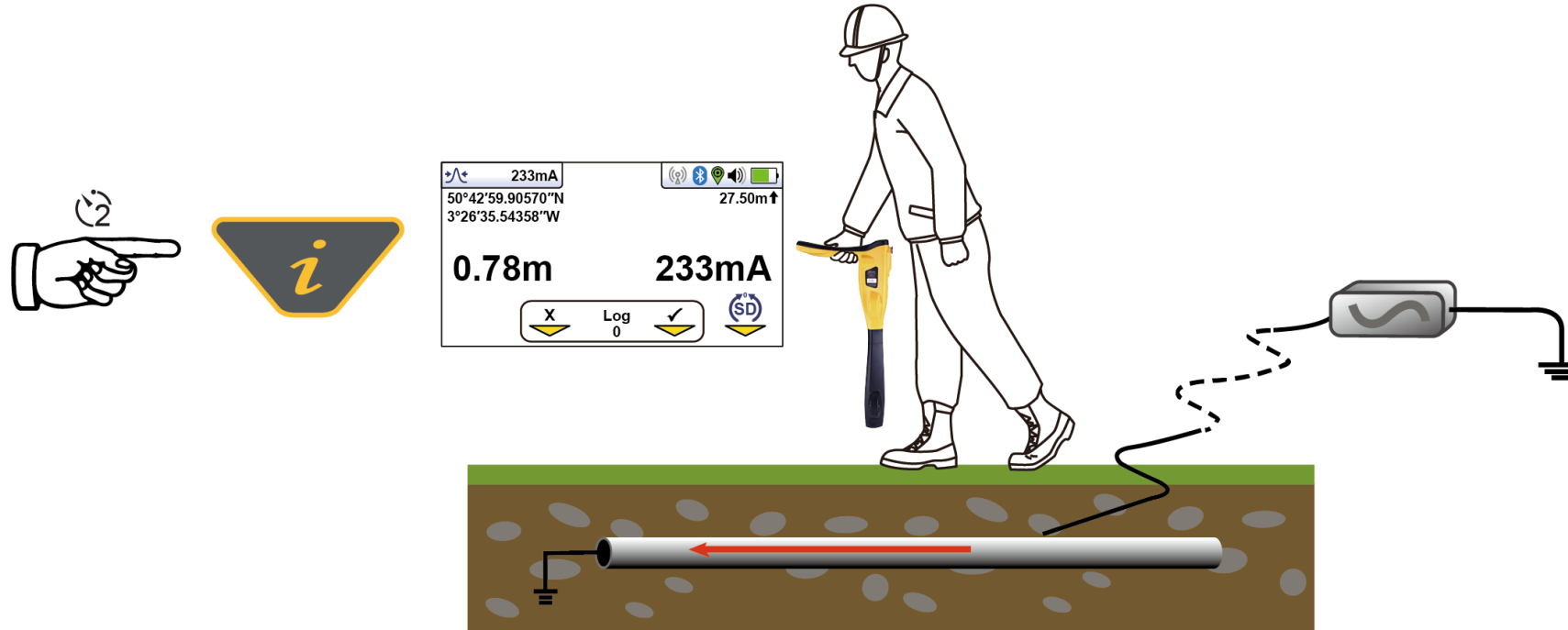

- Continue to locate, pinpoint and trace.

# Electronic Marker System (EMS)



## There are two types of EMS Locators

### – Dual or Fixed

- The locator is a typical pipe and cable locator with a fixed or built-in Marker locator.

### – Plug-in-Play Adapter

- A pipe and cable locator with an add-on EMS marker adapter, which is plugged in when needed to locate a buried marker

**Both can perform a utility locate and EMS Locate at the same time**



# Types of EMS Marker

EMS markers mark below-ground points of interest, such as splice joints or buried valves. They also mark the position and route of non-metallic services such as plastic pipes.

**Markers vary in size and shape, typical ones are :**

Near surface marker – range 600mm









Ball marker – range 1.5m



Full range marker – range 2.4m



**EMS markers are used to distinguish different utilities with a specific colour and frequency.**

 TELEPHONE	Cable paths, buried splices, buried service drops, load coils, conduit stubs, fiber optic facilities, all types of splices, bends depth changes, manhole covers, road crossings
 POWER	Cable paths, service drops, conduit stubs, road crossings, all types of splices, buried transformers, service loops, street lighting, bends, manhole covers, distribution loops
 CATV	Cable paths, fiber optic facilities, buried service drops, road crossings, buried splices, bends
 GENERAL PURPOSE	Reclaimed water, private campuses, valve boxes, road crossings, path marking, buried valves, tees, meter boxes, main stubs, service stubs
 WATER	Pipeline paths, service stubs, PVC pipeline, all types of valves, road crossings, tees, clean-outs, casing ends
 WASTEWATER	Valves, all types of fittings, clean outs, service stubs, laterals, path marking of non-metallic facility
 GAS	Pipeline paths, main stubs, service stubs, tees, road crossings, all types of valves, meter boxes, stopping fittings, depth changes, transition fittings, squeeze points, pressure control fittings, electro fusion couplings, all types of fittings and joints



## An EMS marker consists of a coil of wire with a resonating capacitor

- To imagine the resonance, consider the audio equivalent
- Imagine a glass being tapped. The glass will resonate at the natural frequency of the glass in a similar way the EMS marker electronically resonates at its resonant frequency.

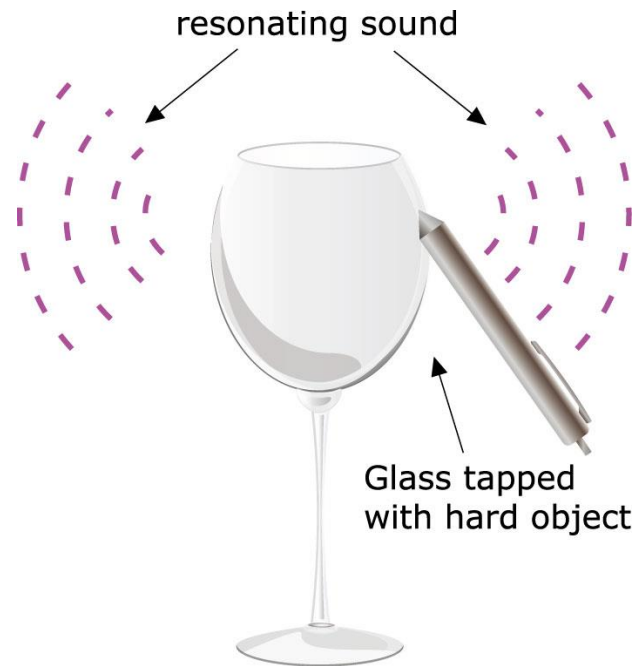

# Electronic Marker Systems (EMS) - Theory

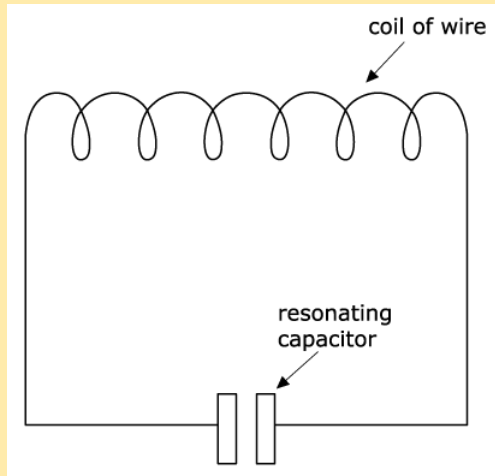

An EMS marker consists of a coil of wire connected in parallel with a resonating capacitor.

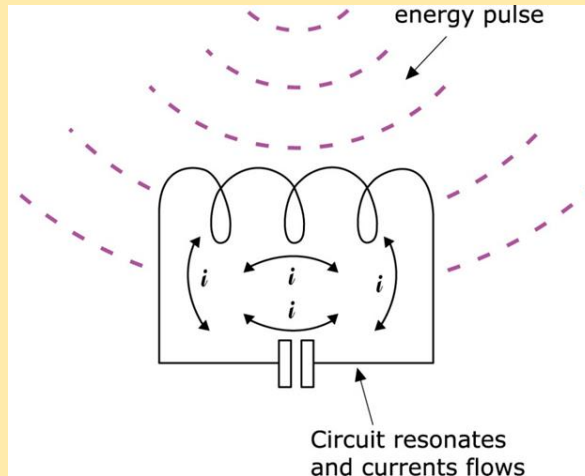

The coil and capacitor are chosen to have a particular resonant frequency.

When the circuit is hit with a pulse of electromagnetic energy, the circuit resonates, causing currents to flow in the circuit.

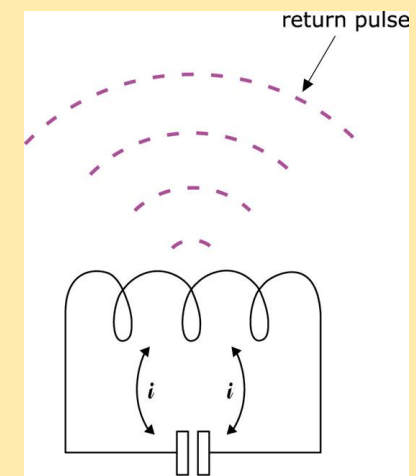

Currents flowing in the EMS marker create a return signal.



# Electronic Marker Systems (EMS) - Theory

- The original pulse is created by the EMS locator above ground which energizes the transmitting coil in the EMS marker below ground.



**vLoc3-ML  
Utility and  
Marker Locator**



**vLoc3-Pro  
Utility Locator  
with MLA**



# Fault Locating



## A-Frame fault locators

Typical applications

- Finding sheath to ground/earth faults
- Evaluating the condition of pipe coating (Holidays)

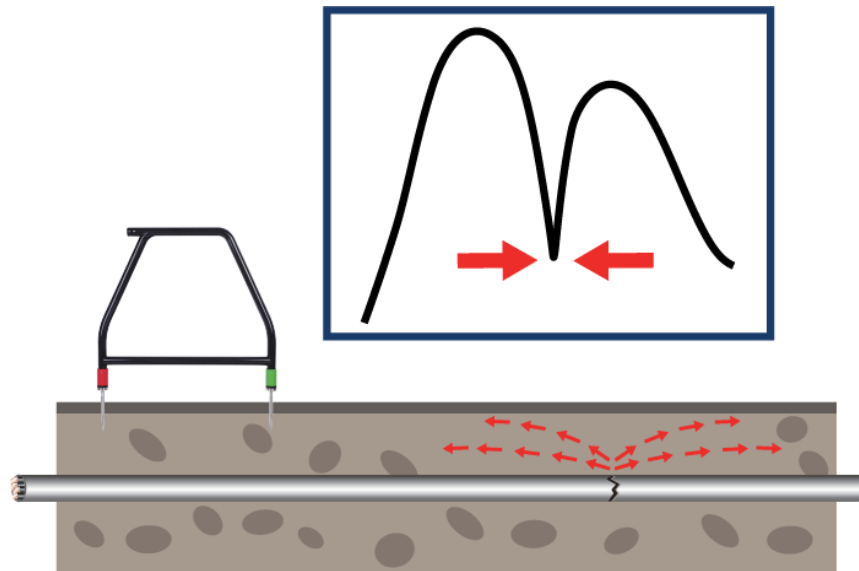

**Accessory A-frame – Plugs into the vLoc3 series receivers**



**VM-510FFL+ Line locator and fault locator**

# Fault Locating

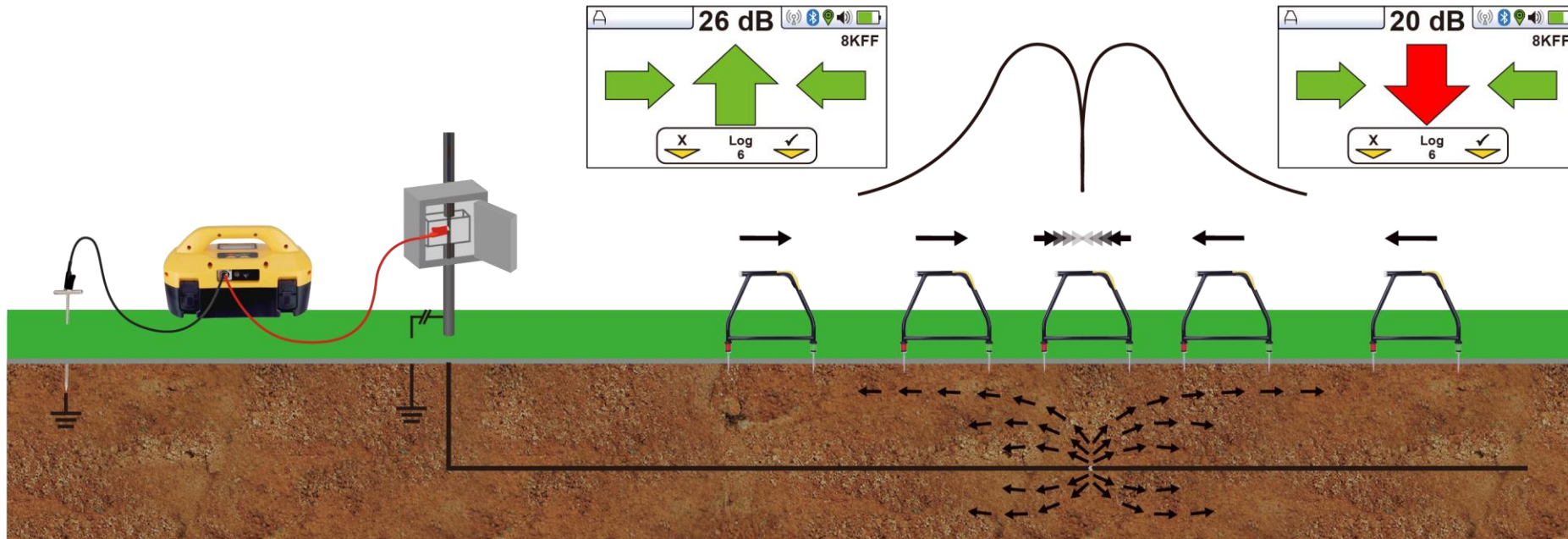

Disconnect all ground connections to encourage the signal to travel through the fault to earth and not a ground somewhere else.

Set both the receiver and transmitter to 8KFF mode

## Cable and Pipeline Fault Locating

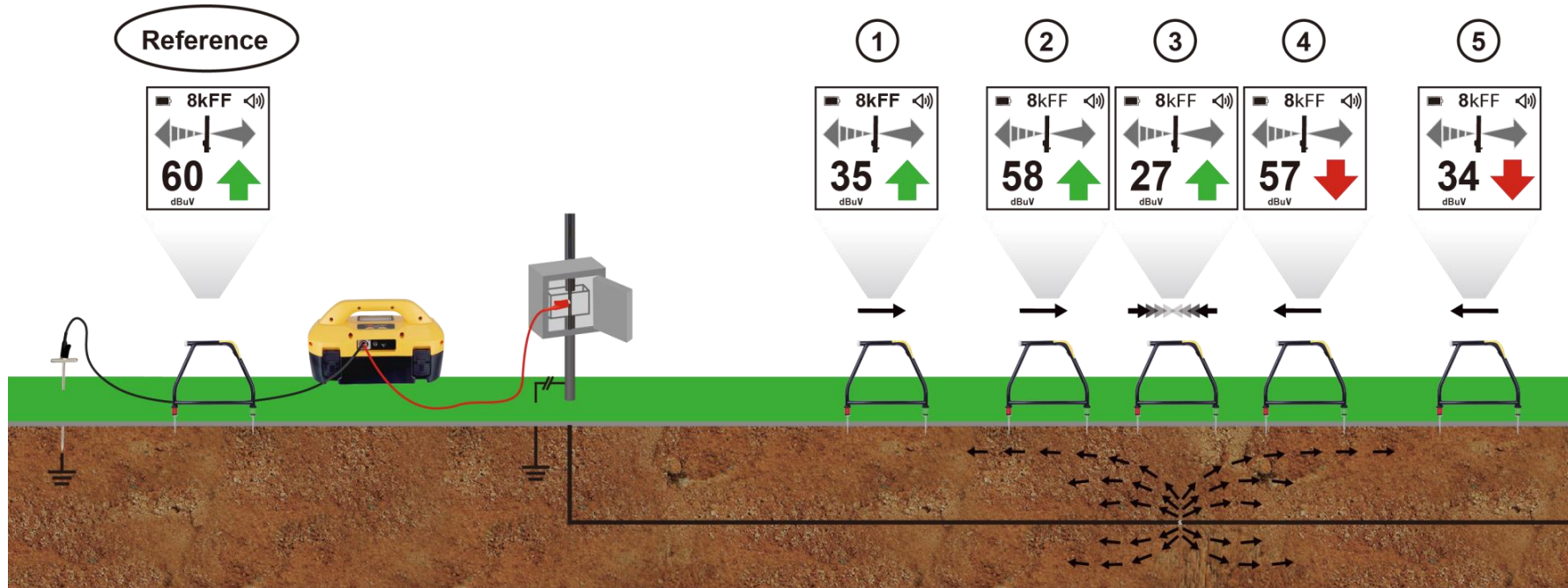

- If it is suspected that there is just one fault on the line, the A-frame can be used to estimate the magnitude of the fault.
- Position the A-frame approximately the same distance from the ground stake as the suspected depth of the faulted cable. Note the dB reading. You should see a similar dB reading as you get close to the fault.
- For best results, the faulted line must be completely isolated and all ground/bonds removed.

## Cable and Pipeline Fault Locating

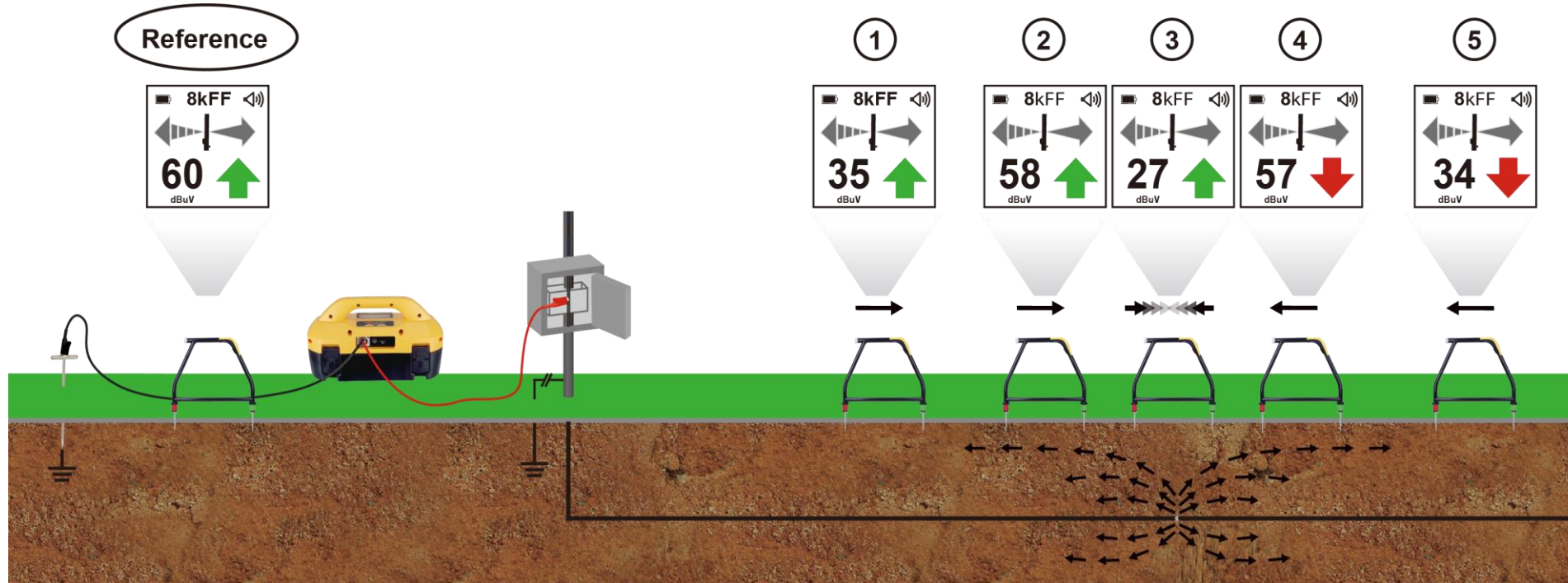

- As you get closer to the Fault, the dB reading should start to increase
- As the fault passes, the arrow will flip to point reverse. When the spikes of the A-frame are over the fault, the dB reading will drop. Continue forward until the arrow reverses, then make small movements forwards and backward to pinpoint the fault under the center of the A-Frame.
- Make a mark on the ground in the suspected location

## Cable and Pipeline Fault Locating

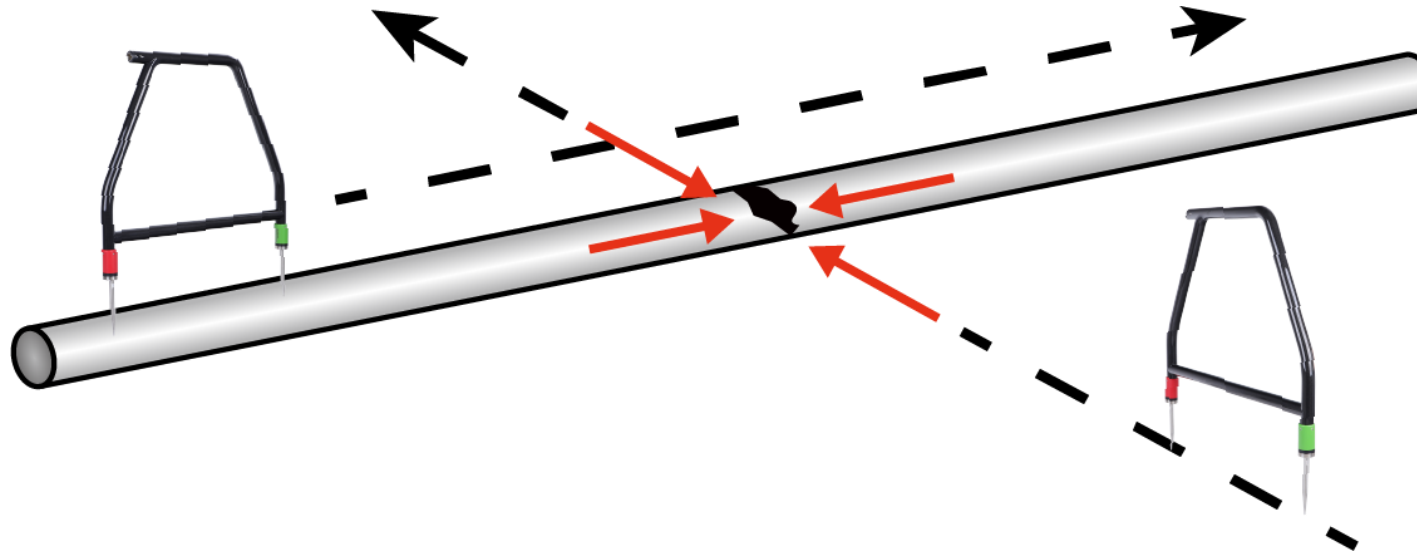

- Repeat the process at 90° to your previous direction. The two lines should intersect at the location of the fault.
- To fully confirm and pinpoint the fault, place the green spike in the ground at that point and rotate the A-Frame in a circle placing the red spike in the ground several times; if the arrow remains Facing forward and green, the fault is directly beneath the green spike.

# Vivax-Metrotech Worldwide Locations

## Vivax-Metrotech Ltd.

Unit 1, B/C Polden Business Centre,  
Bristol Road, Bridgwater, Somerset,  
TA6 4AW, UK  
Tel: +44(0)1793 822679  
Email: SalesUK@vxmt.com

## Metrotech Vertriebs GmbH

Am steinernen Kreuz 10a  
96110 Schesslitz, Germany  
Tel: +49 9542 77227-43  
Email: SalesEU@vxmt.com

## Vivax Canada Inc.

41 Courtland Ave Unit 8, Vaughan,  
ON L4K 3T3, Canada  
Tel: +1-289-846-3010  
Fax: +1-905-752-0214  
Email: SalesCA@vxmt.com

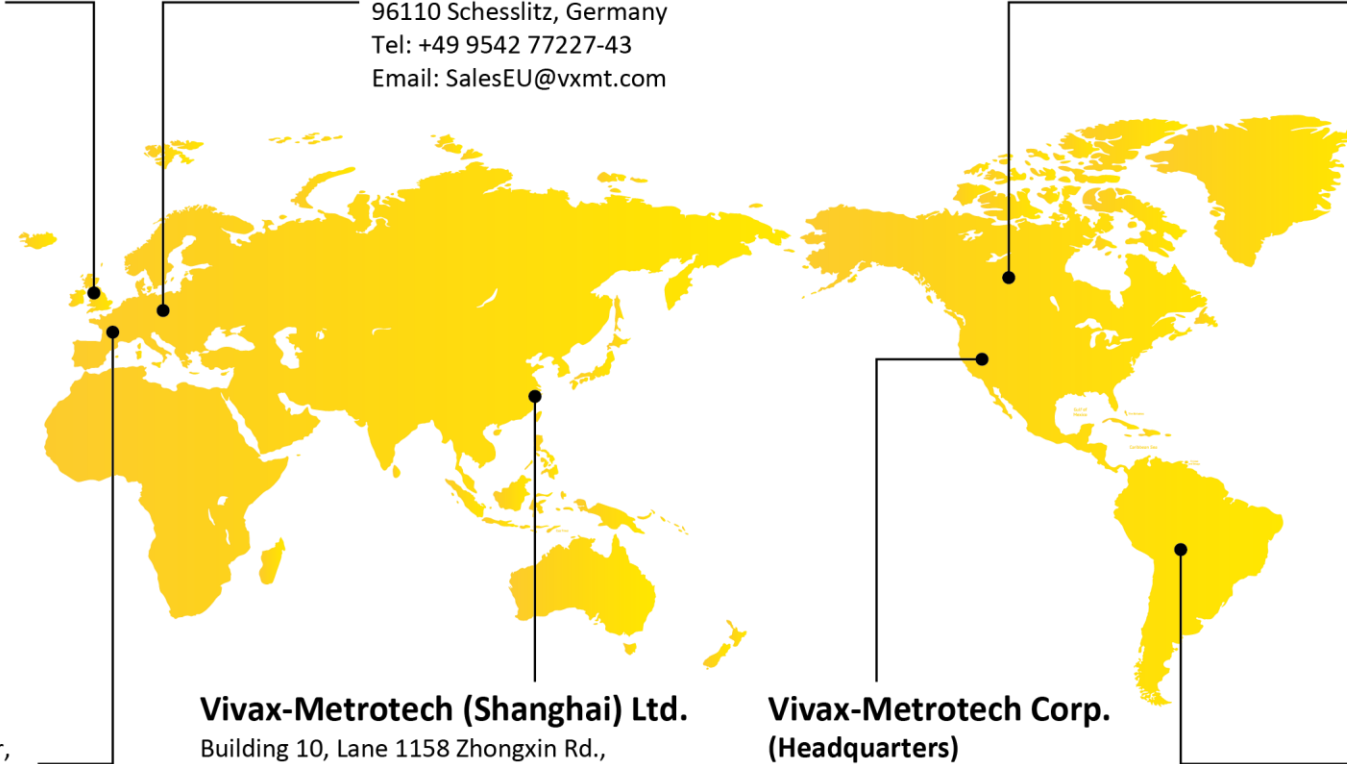

## Vivax-Metrotech SAS

Technoparc - 1 allée du Moulin Berger,  
69130 Ecully, France  
Tel: +33 (0)472 53 03 03  
Fax: +33 (0)472 53 03 13  
Email: SalesFR@vxmt.com

## Vivax-Metrotech (Shanghai) Ltd.

Building 10, Lane 1158 Zhongxin Rd.,  
Songjiang District, Shanghai, China 201615  
Tel: +86-21-5109-9980  
Email: SalesCN@vxmt.com.cn

## Vivax-Metrotech Corp. (Headquarters)

3251 Olcott Street, Santa Clara,  
CA 95054, USA  
T/Free: 1-800-446-3392  
Phone: +1-408-734-3880  
Fax: +1-408-734-1415  
Email: SalesUSA@vxmt.com

## Ventas para América Latina

3251 Olcott Street, Santa Clara, CA 95054, USA  
T/Free: 1-800-446-3392  
Tel: +1-408-734-3880  
Fax: +1-408-743-5597  
Email: LatinSales@vxmt.com





***The End***



***Please visit us on the web to see our full line of Camera Systems, Utility Locators,  
Metal Detectors, and Specialty Locators***

**[www.vivax-metrotech.com](http://www.vivax-metrotech.com)**

**[www.vivax-metrotech.de](http://www.vivax-metrotech.de)**

**[www.vivax-metrotech.ca](http://www.vivax-metrotech.ca)**

**[www.vivax-metrotech.co.uk](http://www.vivax-metrotech.co.uk)**

**[www.vivax-metrotech.fr](http://www.vivax-metrotech.fr)**

Please send any comments or suggestions regarding this PowerPoint presentation to [marketing@vxmt.com](mailto:marketing@vxmt.com)