



# **vCamMX-2<sup>+</sup> Mini System**

## **User Manual**

Vivax-Metrotech Corporation

4.04.000254 04/01/2024 V1.0



# General Safety & Care Information

## ◆ Health and Safety

This equipment is primarily used by professionals in the sewer and plumbing industry to inspect sewer pipes. It is maintained by professionals familiar with the health risks of maintaining equipment in a sewer.

Such professionals will be protected by their company's recommendations and work practices. If for any reason they are not or are not familiar with such practices, please check our website or email SalesUSA@vxmt.com for a copy of the Health and Safety Document used by Vivax-Metrotech for employees involved in the demonstration, maintenance, and handling of sewer camera systems.

- Keep all electrical connections dry and off the ground.
- Be aware of your surroundings at all times. Cone off open utility holes and follow traffic control regulations.
- Use personal protection such as eyewear, rubber gloves, and non-skid safety shoes.

## ◆ Worksite Safety

- Use your company's or other applicable safety codes and rules when using this equipment.
- **Do not** use this equipment in explosive areas – such as in the presence of flammable liquids, gases, and heavy dust.

## ◆ Equipment Safety

- **Do not** open the enclosures (housings) of the reel or camera heads.
- Opening the housings or camera head will void any warranty.
- Use only the leads supplied with the control module for AC or DC operation and charging.

## ◆ Batteries and the Environment

This Vivax-Metrotech product uses a rechargeable Lithium-Ion battery and a Lithium metal watch battery.

## ◆ Heat from camera head LEDs



The camera head may become hot when left on while not performing an inspection. Handle the camera head with care when it is sitting outside

of the pipe for extended periods. We recommend using the camera skid and turning down the LEDs. The camera LEDs will automatically turn off after 5 minutes of no activity. No activity is triggered by the pushrod drum not spinning after 5 minutes.

## ◆ High-Pressure Water or Pressure Washers



**Do not** use pressure washers to clean the reel or other camera system parts.

## ◆ Bleach and chemicals - Do not soak the termination parts or camera heads



**Do not** soak the spring termination parts or the camera heads in bleach or other chemicals.

## ◆ Intended Use

This product is designed to inspect sewer laterals and basic indoor and outdoor plumbing. This product is not designed for and should not be used to inspect oil or other petrochemical pipes.

## ◆ FCC & IC Statement

Please note that changes or modifications not expressly approved by the party responsible for compliance could void the user's authority to operate the equipment.

This device complies with Part 15 of the FCC Rules. Operation is subject to the following two conditions:

- (1) This device may not cause harmful interference, and
- (2) This device must accept any interference received, including interference that may cause undesired operation.

This device complies with Industry Canada license-exempt RSS standard(s). Operation is subject to the following two conditions:

- (1) This device may not cause interference, and
- (2) This device must accept any interference, including interference that may cause undesired operation of the device.

Le présent appareil est conforme aux CNR d'Industrie Canada applicables aux appareils radioexemptés de licence. L'exploitation est autorisée aux deux conditions suivantes:

- (1) l'appareil ne doit pas produire de brouillage, et
- (2) l'utilisateur de l'appareil doit accepter tout brouillage radioélectrique subi, même si le brouillage est susceptible d'en compromettre le fonctionnement.

Under Industry Canada regulations, this radio transmitter may only operate using an antenna of a type and maximum (or lesser) gain approved for the transmitter by Industry Canada. To reduce potential radio interference to other users, the antenna type and its gain should be so chosen that the equivalent isotropically radiated power (e.i.r.p.) is not more than that necessary for successful communication.

Conformément à la réglementation d'Industrie Canada, le présent émetteur radio peut fonctionner avec une antenne d'un type et d'un gain maximal (ou inférieur) approuvé pour l'émetteur par Industrie Canada. Dans le but de réduire les risques de brouillage radioélectrique à l'intention des autres utilisateurs, il faut choisir le type d'antenne et son gain de sorte que la puissance isotrope rayonnée équivalente (p.i.r.e.) ne dépasse pas l'intensité nécessaire à l'établissement d'une communication satisfaisante.

◆ **5G Wi-Fi IC Statement**

- (i) the device for operation in the band 5150-5250 MHz is only for indoor use to reduce the potential for harmful interference to co-channel mobile satellite systems;
- (ii) the maximum antenna gain permitted for devices in the bands 5250-5350 MHz and 5470-5725 MHz shall comply with the e.i.r.p. limit; and
- (iii) the maximum antenna gain permitted for devices in the band 5725-5825 MHz shall comply with the e.i.r.p. limits specified for point-to-point and non point-to-point operation as appropriate.

- (i) Les dispositifs fonctionnant dans la bande 5150-5250 MHz sont réservés uniquement pour une utilisation à l'intérieur afin de réduire les risques de brouillage préjudiciable aux systèmes de satellites mobiles utilisant les mêmes canaux.
- (ii) le gain d'antenne maximal autorisé pour les appareils dans les bandes 5250-5350 MHz et 5470-5725 MHz doivent respecter le pire limiter; et
- (iii) le gain d'antenne maximal autorisé pour les appareils dans la bande 5725-5825 MHz doivent respecter le pire limites spécifiées pour le point-à-point et l'exploitation non point à point, le cas échéant.

# Table of Contents

1. Service & Support.....	1
1.1 Model and Serial Number Location.....	1
1.1.1 Control Module and Reel Serial Number Location.....	1
1.1.2 Location of the camera Head Serial Number.....	1
1.2 Software Revision Information.....	1
1.3 Request for Service.....	3
1.4 Worldwide Sales Offices and Service Centers.....	3
2. Introduction.....	4
2.1 The vCamMX-2+ Inspection Camera System.....	4
2.2 Icon Gallery.....	4
2.3 What's in the box.....	5
2.4 vCamMX-2+ Series Control Module Overview.....	6
2.5 Type-MX Cable Reel Overview.....	9
2.6 Control Module Adjustments.....	10
2.7 Video Export from the Control Module.....	10
3. Initial Control Module Setup.....	11
3.1 Initial Control Module Setup.....	11
3.1.1 Installing the Fuse.....	11
3.1.2 Charging the Internal Battery.....	11
3.1.3 About Control Module Settings.....	11
3.2 Navigating through the Setup Menu.....	12
3.2.1 The key used in the setup procedure.....	12
3.2.1.1 Turn on the system.....	12
3.2.1.2 Set the Language.....	12
3.2.1.3 Set the Distance Counter Units.....	12
3.2.1.4 Set the Date and Time.....	13
3.2.1.5 Set the Storage Options.....	13
3.2.1.6 Set the Sonde Frequency.....	14
3.2.1.7 Set the OSD (On Screen Display) Options.....	14
3.2.1.8 Set the File Rename Option.....	14
3.2.1.9 Wi-Fi.....	14
3.2.2 Restore the Factory Default Settings.....	15
3.2.3 Update the Control Module Firmware.....	15
3.2.3.1 Over-the-Air Updates.....	15
3.2.3.2 Manual Update by USB Thumb Drive.....	15
4. Video Recording and Image Capture.....	19
4.1 Overview.....	19
4.2 Making a video recording.....	19
4.2.1 Changing the File Name.....	19
4.2.2 Taking JPEG Pictures.....	20
4.3 Viewing Recorded Videos and Pictures in the Control Module.....	21
4.3.1 vCamMX-2+ File Manager Overview.....	21
4.3.2 Viewing and playing contents of the USB drive or SD Card.....	21
4.3.3 Copying files.....	22
4.3.4 Deleting files.....	22
4.4 MP4 Video Format.....	22
4.5 Troubleshooting Video Playback.....	22
4.6 Corrupt Video Files.....	23
4.7 Other Media Players.....	23
5. Features Available During Recording.....	24

5.1	Voice Over.....	24
5.2	Volume Control.....	24
5.3	Display and Backlight Settings.....	24
5.4	On-Screen Status Bar.....	24
5.5	On-Screen Display (OSD Info).....	25
5.6	Camera LED Light Control.....	25
5.6.1	From the Media Keypad.....	25
5.6.2	From the LCD Keypad.....	26
5.7	On-Screen Text Writer.....	26
5.7.1	Introduction to the On-screen Text Writer.....	26
5.8	JPEG Image Capture.....	29
5.9	Digital Zoom.....	29
6.	Wi-Fi.....	30
6.1	Wi-Fi Connection for Apps.....	30
7.	Using the Reel.....	31
7.1	Pushrod Overview.....	31
7.1.1	Distance Counter Accuracy.....	31
7.1.2	Deployment of the Pushrod Cable.....	32
8.	Camera Heads and Terminations.....	35
8.1	Parts of the Camera Heads.....	35
8.1.1	Camera Head Options.....	35
8.2	Spring Termination Parts.....	36
8.2.1	Termination Parts List.....	36
8.2.2	Pre-checking the Camera Head Before Installing.....	36
8.2.3	Pre-checking for Picture and LED Control.....	36
8.2.4	Pre-checking the Camera Glass Lens and LED Cover.....	37
8.3	Removing and Installing the Camera Head.....	37
8.4	Removing and Installing the Spring Assembly.....	39
9.	Camera Skids.....	40
9.1	Camera Skids.....	40
9.2	Camera and Spring Skids, Installing and Removing.....	40
9.2.1	Standard Skid, Screw in Setscrews.....	40
9.2.2	Standard Skids, Two-part Clip Together.....	41
9.2.3	Guide Skids, Clamp around the Camera Head.....	42
10.	Locating the Camera Sonde and Pushrod.....	43
10.1	Sonde Operation.....	43
10.2	Applying a Locate Signal onto the Pushrod.....	43
11.	Troubleshooting.....	45

# 1. Service & Support

## 1.1 Model and Serial Number Location

Always quote your camera system's model, serial, and software revision numbers when requesting product support.

### 1.1.1 Control Module and Reel Serial Number Location

The control module assembly consists of two major parts: the LCD assembly and the control box assembly. The serial number for the vCamMX-2+ control box is found on the back of the control box.

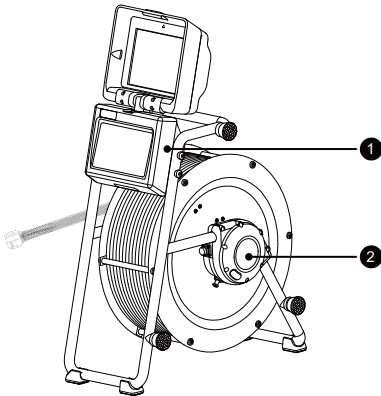

- ① Control module serial number
- ② Type-MX Reel serial number

### 1.1.2 Location of the camera Head Serial Number

The serial numbers can be found etched across the camera's length or the camera housing's recessed area. The camera skid must be removed to view the serial number of the camera head.

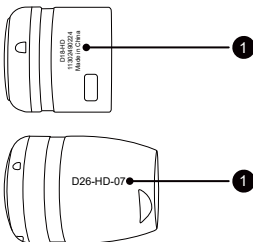



- ① Camera head serial number

## 1.2 Software Revision Information

The "System" screen in the setup menu shows the control module's firmware (software) version and release date.

The vCamMX-2+ series firmware updates come as a ".mxip" extension file. The firmware files can be obtained at [www.vivax-metrotech.com](http://www.vivax-metrotech.com), an authorized service center, distributor, or a local Vivax-Metrotech office.

To view the control module's current firmware version, follow these steps:

1. Press the "Setup"  key to bring up the sub-menu.
2. Press the "System"  key to enter the sub-menu.

The firmware revision is shown on the right side of the label "Version."



**In July 2023, Vivax-Metrotech stopped manufacturing SD (standard definition) camera heads. In July 2023, we introduced our of HD (high definition) interchangeable camera heads for the vCamMX-2+ and vCamDrain inspection systems.**

The label below on the Firmware Update screen shows compatibility information on the camera heads.

- The firmware version must be 3.7.59 or greater to read HD camera heads.
- The space to the right of the TP2825B field must read YES to work with the HD camera heads. A Video Processor upgrade must be performed on the vCamMX-2+ control module if it reads NO. Contact the factory or authorized repair center for more information.
- The Camera Type field will tell if the connected camera head is SD or HD.

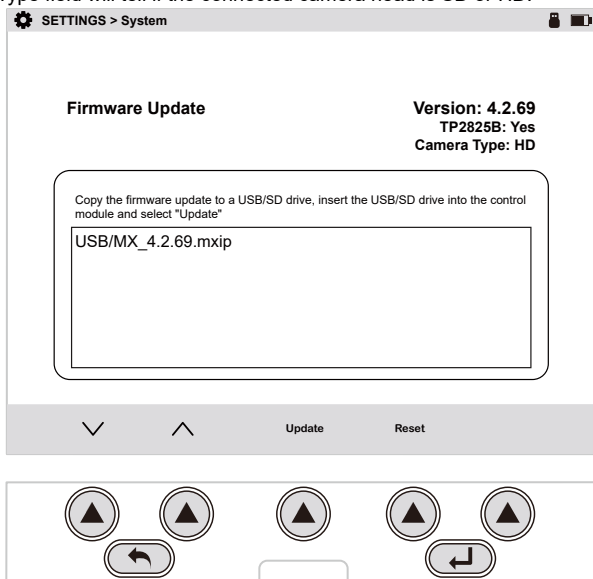

**vCamMX-2+ firmware version of "4.2.69 and above can use the VMC app to perform Over The Air firmware updates. When the vCamMX-2+ control module is connected to the VMC app, the app can perform an over-the-air firmware update.**

**Make a note the control module's current software version before running the update. You can compare the before and after versions when the update is completed.**

### 1.3 Request for Service

If any system components need servicing, the more concise information provided, the quicker the turnaround time will be. On our website, you can fill out a "Service Center Request" form, print it, and include it with the unit when shipping. If the unit must be returned, package it well and ship it by a traceable method.

### 1.4 Worldwide Sales Offices and Service Centers

#### Worldwide Sales Offices and Service Centers

#### World Headquarters, United States of America

##### Vivax-Metrotech Corporation

3251 Olcott Street, Santa Clara,  
CA 95054, USA  
T/Free: 1-800-446-3392  
Tel: +1-408-734-3880  
Fax: +1-408-904-4964  
Website: [www.vivax-metrotech.com](http://www.vivax-metrotech.com)  
Email: [SalesUSA@vxmt.com](mailto:SalesUSA@vxmt.com)

#### Canada

##### Vivax Canada Inc.

41 Courtland Ave Unit 8,  
Vaughan, ON L4K 3T3, Canada  
Tel: +1-289-846-3010  
Fax: +1-905-752-0214  
Website: [www.vivax-metrotech.ca](http://www.vivax-metrotech.ca)  
Email: [SalesCA@vxmt.com](mailto:SalesCA@vxmt.com)

#### Germany

##### Metrotech Vertriebs GmbH

Am steinernen Kreuz 10a,  
96110 Schesslitz, Germany  
Tel: +49 9542 77227-42  
Website: [www.vivax-metrotech.de](http://www.vivax-metrotech.de)  
Email: [SalesEU@vxmt.com](mailto:SalesEU@vxmt.com)

#### China

##### Vivax-Metrotech (Shanghai) Ltd.

Building 10, Lane 1158 Zhongxin Rd.,  
Songjiang District, Shanghai, China, 201615  
Tel: +86-21-5109-9980  
Website: [www.vivax-metrotech.com](http://www.vivax-metrotech.com)  
Email: [SalesCN@vxmt.com.cn](mailto:SalesCN@vxmt.com.cn)

#### Central/South America and the Caribbean

##### Ventas para América Latina

3251 Olcott Street,  
Santa Clara, CA 95054, USA  
T/Free: 1-800-446-3392  
Tel: +1-408-734-3880  
Fax: +1-408-743-5597  
Website: [www.vivax-metrotech.com](http://www.vivax-metrotech.com)  
Email: [LatinSales@vxmt.com](mailto:LatinSales@vxmt.com)

#### France

##### Vivax-Metrotech SAS

Technoparc - 1 allée du Moulin Berger,  
69130 Ecully, France  
Tel: +33(0)4 72 53 03 03  
Fax: +33(0)4 72 53 03 13  
Website: [www.vivax-metrotech.fr](http://www.vivax-metrotech.fr)  
Email: [SalesFR@vxmt.com](mailto:SalesFR@vxmt.com)

#### United Kingdom

##### Vivax-Metrotech Ltd.

Unit 1, B/C Polden Business Centre,  
Bristol Road, Bridgwater, Somerset,  
TA6 4WA, UK  
Tel: +44(0)1793 822679  
Website: [www.vivax-metrotech.co.uk](http://www.vivax-metrotech.co.uk)  
Email: [SalesUK@vxmt.com](mailto:SalesUK@vxmt.com)

















## 2. Introduction

### 2.1 The vCamMX-2+ Inspection Camera System

The vCamMX-2+ Inspection System consists of three major components: vCamMX-2+ Control Module, Type-MX Reel with Pushrods, and Camera Heads.

### 2.2 Icon Gallery

This section lists the icons shown in the vCamMX-2+.

Icon	Name	Description
<b>Control Box Icons</b>		
	<b>On/Off Button</b>	Press and release to <b>turn the unit on</b> . When on this button will glow green. Press and hold to turn the unit off.
	<b>Distance reset</b>	Pressing this button will <b>reset the distance counter to zero</b> .
	<b>Microphone</b>	Press this button to <b>turn the internal microphone on and off</b> .
	<b>Sonde</b>	Pressing this button will <b>activate and deactivate the sonde</b> .
	<b>Record</b>	Press this button to <b>start a recording</b> .
	<b>Picture</b>	Press this button to <b>take a JPEG picture</b> .
	<b>Zoom</b>	Press this button to <b>enter the digital zoom mode</b> .
	<b>Playback controls</b>	Use the keys while playing videos on the USB drive to control the camera lights and the on-screen keyboard.
<b>LCD Menu Icons</b>		
	<b>Enter</b>	Press this key when required to <b>complete an action</b> . Press this key to <b>hide and show the main menu bar</b> while viewing and recording.
	<b>Step Back / ESC</b>	Press this key to <b>return to the previous screen or exit an operation</b> .
	<b>Karat choice keys</b>	Press these keys to <b>make a selection</b> while in various menus.
	<b>Files</b>	Press this key to enter the <b>File Manager</b> to manage video and picture files.
	<b>Display</b>	Press this key to access the <b>LCD's settings</b> .
	<b>OSD</b>	Press this key to <b>change the colors and position of the date, distance and time</b> shown on the screen.
	<b>Lights</b>	Use this key to <b>adjust the camera lights</b> .
	<b>Setup</b>	Use this key to <b>enter the systems setup</b> options for Region, storage, systems and Wi-Fi settings.

## 2.3 What's in the box

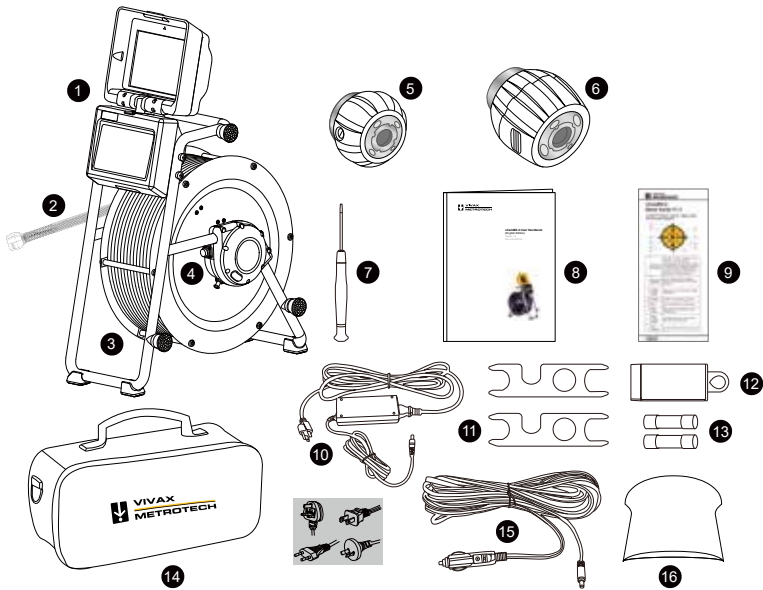

- |   |   |    |   |
|---|---|----|---|
| 1 | vCamMX-2+ Control Module                | 9  | Quick Guide   |
| 2 | MX Spring assembly                      | 10 | Charger with power cable  |
| 3 | Type-MX Reel with Pushrod               | 11 | MX-2+ Camera and spring tools   |
| 4 | MX Interconnect cable with covers       | 12 | USB Thumb drive   |
| 5 | D18-HD Camera Head with Standard Skid * | 13 | Fuse  |
| 6 | D26-HD Camera Head with Standard Skid * | 14 | Accessory Bag with accessories<br>(Numbers 7, 8, 9, 10, 11, 12, 13, 15<br>and 16) |
| 7 | Flat 2.5mm screwdriver for the skid     | 15 | DC Power Lead   |
| 8 | User Manual                             | 16 | Pipe insertion sleeve   |

\* The camera head you will received was selected at the time of ordering.

## 2.4 vCamMX-2+ Series Control Module Overview

The vCamMX-2+ control module records and plays back MP4 videos and JPEG images. Audio and text comments can be added to the videos and text comments can be added to the JPEG images.

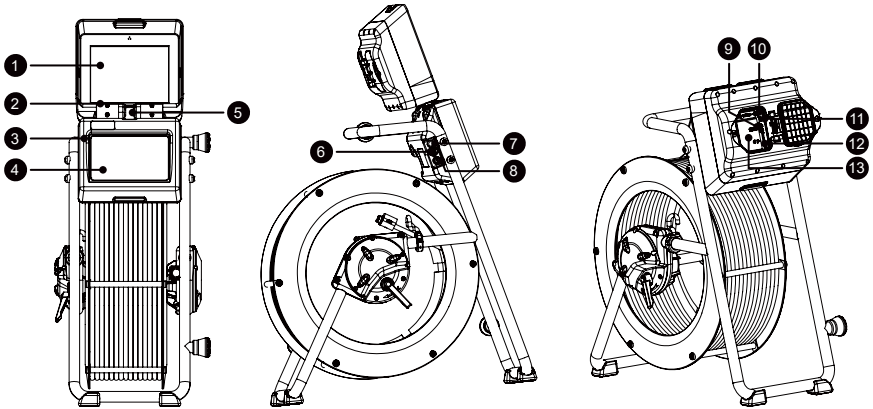

The system's time, date, and distance of the deployed pushrod are added to both video and pictures.

The following describes the features of the control module:











- |                           |                     |
|---------------------------|---------------------|
| ① LCD                     | ⑧ Fuse compartment  |
| ② LCD keypad              | ⑨ Mini-USB port     |
| ③ Control box             | ⑩ SD Card slot      |
| ④ Main keypad             | ⑪ USB-A port        |
| ⑤ LCD swivel post         | ⑫ Video-out port    |
| ⑥ AC/DC power lead socket | ⑬ Media compartment |
| ⑦ Charging indicator      |                     |

## LCD Menu Icons

	<b>Step Back / ESC</b>	Press this Key to return to the previous screen or exit an operation.
	<b>Karat choice keys</b>	Press these keys to select while in various menus.
	<b>Enter</b>	Press this Key when required to complete an action. Press this Key to hide and show the main on-screen menu while viewing and recording.

## Control Box Buttons

	<b>On/Off Button</b>	Press and release to turn the unit on. When on, this button will glow green. Press and hold to turn the unit off.
	<b>Distance reset</b>	Pressing this button will reset the distance counter to zero. A message will momentarily appear on the top screen, confirming that the counter has been reset.
	<b>Microphone</b>	Press this button to turn the internal microphone on and off. The button will glow red, and the microphone icon will be shown in the status bar. Stand between one and three feet/1m of the screen and speak facing the screen. The internal microphone is located at the top center above the screen.
	<b>Sonde</b>	Pressing this button will activate and deactivate the sonde. With each press of the button, the sonde frequency will change. After cycling through the frequencies, the sonde will turn off. The button will glow green when active, and the sonde frequency will appear in the status bar.
	<b>Record</b>	Press this button to start a recording. The button will glow red when active, and the record icon will appear in the status bar. Press this button again to end the recording.
	<b>Picture</b>	Press this button to take a JPEG picture. When pressed, a message will appear on the top center screen to confirm the successful picture capture.
	<b>Zoom</b>	Press this button to enter the digital zoom mode. One press will zoom x 2, press again to zoom x 3 and press again to exit the zoom mode. The zoom level will be shown in the status bar.
	<b>Playback controls and Camera lights</b>	While viewing or recording: Use the Left/Right Arrow section to increase or lower the camera lights. Use the Pause/Resume button while recording or playing a video to pause and resume the video. To rename a file, Use these buttons to navigate the on-screen keyboard, which appears when a recording is stopped. Use the center Enter button to select the letters to name the file. While playing a video: Use these buttons to Pause, Forward Fast, Stop and Rewind the video playing.

## vCamMX-2+ Playback Controls, Camera Lights and On-screen Keyboard

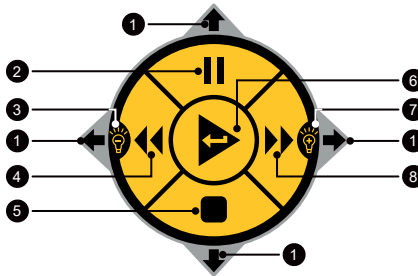

- |                                     |  |
|-------------------------------------|--|
| <p>① <b>Keyboard Navigation</b></p> | <p>While the file rename dialog box is on the screen, use the buttons corresponding to the top, right, bottom, and left arrows to navigate through the on-screen keyboard. Navigate to and press the next Key on the on-screen keyboard to save the changes.</p> |
| <p>② <b>Pause and Resume</b></p>    | <p>Use this button while recording or playing a video to pause and resume the video.</p>   |
| <p>③ <b>Lower Camera Lights</b></p> | <p>Lower the camera lights while viewing or recording.</p>   |
| <p>④ <b>Rewind</b></p>              | <p>Rewind the video during playback.</p>   |
| <p>⑤ <b>Stop</b></p>                | <p>Stop the recording or playing the video.</p>  |
| <p>⑥ <b>Enter Button</b></p>        | <p>Press while in File Manager to play a selected video.</p>   |
| <p>⑦ <b>Raise Camera Lights</b></p> | <p>Increase or lower the camera lights while viewing or recording.</p>   |
| <p>⑧ <b>Fast Forward</b></p>        | <p>Fast forward through the playing video.</p>   |

## 2.5 Type-MX Cable Reel Overview

The Type-MX cable reels are used to store and control the deployment of the pushrod cable.

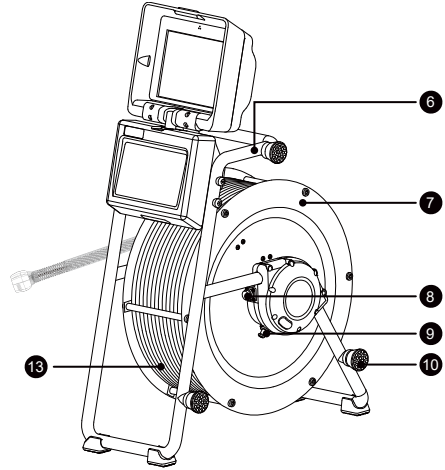
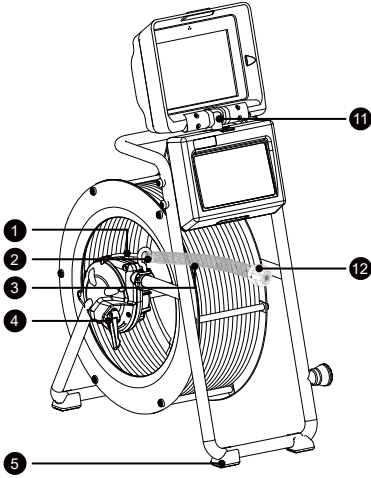

- 1 Cable guide
- 2 Sonde
- 3 Termination spring
- 4 Friction/locking brake
- 5 Rubber feet
- 6 Frame
- 7 Cable drum

- 8 Pushrod trace post
- 9 Interconnect cable socket
- 10 Horizontal position feet
- 11 LCD swivel
- 12 Camera head
- 13 Pushrod

## 2.6 Control Module Adjustments

The swivel assembly allows the LCD compartment to rotate approximately 60-degrees rotation left or right from the starting point.



**Do not rotate the LCD compartment further than 60-degrees left or right from the starting point. Doing so can cause internal damage to the swivel assembly and internal wiring.**

**Do not rotate past this point**

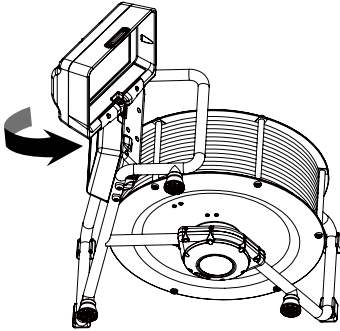

**Open brake and rod deployment side**

**Do not rotate past this point**

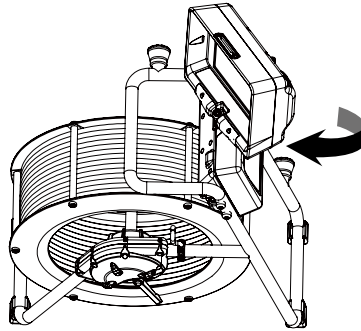

**The closed backside of the reel**

## 2.7 Video Export from the Control Module

Export the raw video feed from the control module into external monitors or computers running LACP software. The control module offers two methods: a) by the USB-Mini port or b) the Video Out Socket.

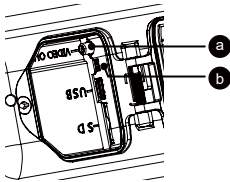

- a. Use a Mini-USB cable to export the video to an LACP software computer. The computer will see the control module as a web camera.
- b. Use an RCA video cable to export the video to a monitor or an LACP software computer.



**In both methods, the raw video can be exported. Raw video does not show the OSD consisting of the Date, Distance and Time.**

**A Video Capture Card may be needed to convert the video into a format that the LACP software can recognize.**

**Please consult with the LACP software manufacturer for compatibility with their software.**

## 3. Initial Control Module Setup

### 3.1 Initial Control Module Setup

#### 3.1.1 Installing the Fuse

Install the 10 Amp - 250 Volt fuse in the fuse compartment on the side of the control module. The control module will operate without a fuse when using AC power, but the battery will not charge, and the unit will turn off when the AC power is removed.

The fuse holder is located on the left side of the control module. Two 10 Amp 250 Volt fuses are included in the control module accessory bag, one for the unit and a spare.

1. Use a screwdriver to unscrew and remove the fuse holder cap. Use the correct size screwdriver to prevent breaking the fuse holder slot.

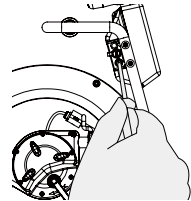

2. Insert the 10 Amp 250 Volt fuse into the fuse holder cap.

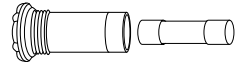

3. Screw the fuse holder cap into the control module by hand, then use a screwdriver to tighten it.

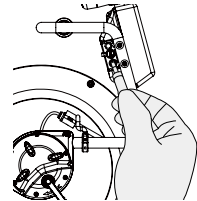

#### 3.1.2 Charging the Internal Battery

Plug the supplied battery charger into the control module's AC/DC charging socket. The charging icon on the left side panel will glow red and glow green when fully charged. The typical charging time to fully charge a completely discharged battery will be approximately six hours, providing approximately eight to nine hours of intermittent use.

#### 3.1.3 About Control Module Settings

After the initial setup of the vCamMX-2+ control module, the settings selected are saved into the control module's memory and will remain until changed. Note that the settings will be lost if the unit is reset to factory defaults or the internal battery is disconnected.

The initial control module will set metric or imperial distance, date and time formats, sonde frequencies, language, and file renaming options.

## 3.2 Navigating through the Setup Menu

### 3.2.1 The key used in the setup procedure



**Step Back / ESC**

Press this Key to return to the previous screen or exit an operation.



**Karat choice keys**

Press these keys to select while in various sub-menus.



**Enter**

Press this Key when required to complete an action.  
Press this Key to hide and show the main menu bar while viewing and recording.

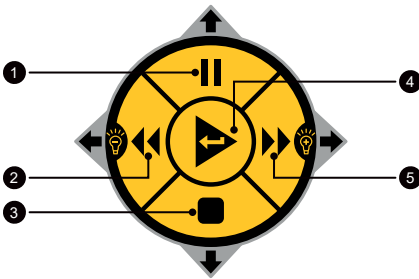





- ① **Move up** Press this Key to move up.
- ② **Move left** Press this Key to move to the left.
- ③ **Move down** Press this Key to move down.
- ④ **Enter** Press this Key to confirm selections.
- ⑤ **Move right** Press this Key to move to the right.

#### 3.2.1.1 Turn on the system







Press and release the Power button  on the control module. The button will glow green, and the operating system will boot up. Turn off the system by pressing and holding the power button.

#### 3.2.1.2 Set the Language

1. Press the **Setup**  Key to enter the Setup sub-menu.
2. Press the **Region**  Key to enter the setup screen.
3. Use the **Up/Down Scroll**  Keys to highlight the desired language.
4. Press the **Enter**  Key to select the language. The updating dialog message will appear until the language change is completed. When completed, the system will return to the main viewing screen.

#### 3.2.1.3 Set the Distance Counter Units

The distance of the pushrod deployed will be shown on the center screen between the time and date. The distance measurement will appear in videos and pictures when this feature is active.







1. Press the **Setup**  Key to bring up the sub-menu.
2. Press the **Region**  Key to enter the regional sub-menu.
3. Use the **Right Scroll**  Key to navigate to the **Measurement** choice list.
4. Use the **Up/Down Scroll**  key to highlight **Meters or Feet**.
5. Press the **Enter**  Key to complete the selection.
6. Press the **ESC**  Key to return to the setup sub-menu, and press again to return to the main viewing screen.

### 3.2.1.4 Set the Date and Time

Setting the Date/Time format allows the choice of three date formats and a 12 or 24-hour time format.

Date formats available are: **MM/DD/YYYY**, **DD/MM/YYYY** and **YYYY/MM/DD**

Time formats available are: **12-hour (08:00 PM)** or **24 hours (20:00)**

1. Press the **Setup**  Key to bring up the sub-menu.
2. Press the **Region**  Key to enter the Regional sub-menu.
3. Use the **Right Scroll**  Key to navigate to the **Time Format** choice list.
4. Use the **Up/Down Scroll**   Keys to highlight the **Date/Time Format** to use.
5. Press the **Enter**  Key to complete the selection.
6. Press the **ESC**  Key to return to the setup sub-menu, and press again to return to the main viewing screen.

### 3.2.1.5 Set the Storage Options

By default, the system will record to the USB drive. The system will record on the SD drive if no USB drive is inserted.

If neither SD nor USB are present, the system will not record.

- **USB Port** – Supports up to 128 GB of removable USB drives.
- **SD Card Slot** – Supports up to 64GB of removable Class 10 SD Cards.

When a USB drive or SD card is inserted, a dialog box will appear on the screen showing the drive size and amount of free space. If this message is not seen the media inserted may be corrupt or incompatible. Drive space can also be checked and media can be formatted by going to **Setup** 

then **Storage** .

Press the **ESC** key twice to return to the main menu screen.

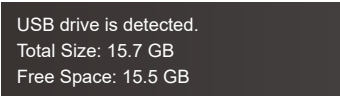



USB drive is detected.  
Total Size: 15.7 GB  
Free Space: 15.5 GB

#### USB Drive Detected Message

**SD Backup** – The SD Backup option will automatically backup the USB drive to the SD Card. This allows the SD card to be used as a solid-state hard drive, keeping copies of the files.

To activate the **SD Backup** option:

1. Press the **Setup**  Key to bring up the Setup sub-menu.
2. Press the **Storage**  Key.
3. Press the Key corresponding to **SD Card Backup**.
4. The USB with SD backup on-screen switch will change from **white (off)** to **yellow (on)**



USB with SD backup  ON

5. Press the **ESC**  key to return to the setup sub-menu, and press again to return to the main viewing screen.

### 3.2.1.6 Set the Sonde Frequency

The vCamMX-2+ contains a choice of three sonde frequencies. The user can activate any of the three frequencies or turn off all three. The system has two low frequencies of 512Hz and 640Hz and one high frequency of 33kHz.

To activate and select the frequencies:



1. Press the **Setup**  Key to bring up the sub-menu.
2. Press the **Features**  Key to enter the Features sub-menu.
3. Press the Key corresponding to the **desired sonde frequency** to use. When pressed, the Key will change the choice from **white (off) to yellow (on)**.



4. Press the **ESC**  key to return to the setup sub-menu, and press again to return to the main viewing screen.

### 3.2.1.7 Set the OSD (On Screen Display) Options

The OSD can be set to appear at the bottom or top of the screen or can be turned off. While active, the OSD information will appear in all recorded videos and JPEG pictures.



1. Press the **Setup**  Key to bring up the sub-menu.
2. Press the **Features**  Key to enter the Features sub-menu.
3. Press the Key corresponding to the OSD. When pressed, the Key will change the choice from **white (off) to yellow (on)**.



4. Press the **ESC**  key to return to the setup sub-menu, and press again to return to the main viewing screen.

### 3.2.1.8 Set the File Rename Option

With the File Rename option, the system can use the system default naming scheme of MMDD\_HRMMSS (month, day, hour, minute, seconds) or prompt to name the file manually.



1. Press the **Setup**  Key to bring up the sub-menu.
2. Press the **Features**  Key to enter the Features sub-menu.
3. Press the Key corresponding to **Rename** to bring up the rename sub-menu.
4. Select the on or off choices for renaming the video or picture files.
5. Press the Key corresponding to the **Video or Pictures**. When pressed, the Key will change the choice from **white (off) to yellow (on)**.



6. Press the **ESC**  Key to return to the Setup sub-menu, and press again to return to the main viewing screen.



### 3.2.1.9 Wi-Fi

The built-in Wi-Fi option allows the vCamMX-2+ to connect to smartphones and tablets. The free vCam Mobile Controller app is available for download from the Apple and Google Play Stores. Visit our website for more information.

1. Press the **Setup**  Key to bring up the sub-menu.
2. Press the **Features**  Key to enter the Features sub-menu.
3. Press the Key corresponding to Wi-Fi to bring up the **Wi-Fi** sub-menu.
4. Press the **ESC**  Key to return to the setup sub-menu, and press again to return to the main viewing screen.

### 3.2.2 Restore the Factory Default Settings

Restoring the default settings will erase all the settings on the control module and return it to the factory default. This will not erase any videos or images on the hard drive.

1. Press the **Setup**  Key to bring up the sub-menu.
2. Press the **System**  Key to enter the System sub-menu.
3. Press the **Reset** Key
4. Confirm that the system should be restored to factory default settings
5. Select the Check Key to start the operation or the **X** Key to cancel
6. Press the **ESC**  Key to return to the setup sub-menu, and press again to return to the main viewing screen.

### 3.2.3 Update the Control Module Firmware

The firmware can be updated by the vCam Mobile Controller app or by downloading the update file and manually installing it via a USB thumb drive.



**Please do not interrupt the update once it has started.**  
**Update the firmware with the control module while running under AC power.**



**Make a note the control module's current software version before running the update. You can compare the before and after versions when the update is completed.**

#### 3.2.3.1 Over-the-Air Updates

All vCamMX-2+ control modules running firmware version 4.4.76 can use the vCam Mobile Controller app to update the control modules firmware.

1. Launch the vCam Mobile Controller app and connect to the vCamMX-2+.
2. If the vCamMX-2+ firmware is outdated or a new update is available, a pop-up dialog box will appear advising so.
 

A new update is now available. Go to Settings -> Over The Air System Update to update the software OK
3. Select OK to proceed with the firmware update.
4. If OK is selected a progress bar indicator will appear during the update.
 

Firmware Update - Installing: 55 %

5. When the update is complete the the unit will reboot and return to the connection screen. The pop-up message will show a countdown to the reconnect screen.
 

**Firmware Update**  
 The Unit was successfully updated and it will be restarted. 48s auto reconnect.
6. After the unit has rebooted you are ready to reconnect to the reel and use it for your next inspection.

#### 3.2.3.2 Manual Update by USB Thumb Drive



**Please do not interrupt the update once it has started.**  
**Update the firmware with the control module while running under AC power.**



**Make a note the control module's current software version before running the update. You can compare the before and after versions when the update is completed.**



**Check our YouTube Channel for an instructional video on manual firmware updates.**

The vCamMX-2+ series firmware updates come as a ".mxip" extension file. The firmware files can be obtained at [www.vivax-metrotech.com](http://www.vivax-metrotech.com), an authorized service center, distributor, or a local Vivax-Metrotech office. **Only USB devices** can be used to perform the update.

The firmware update file must be installed on the **USB device's "root directory."** Specifically, the files must be visible when viewing the contents of the USB device.



**Please do not interrupt the update once it has started. Update the firmware with the control module while running under AC power.**



**Note the control module's current software version before running the update. You can compare the before and after versions when the update is completed.**

After the software has been downloaded and copied to a USB thumb drive, follow the below instructions.

1. Plug the USB device loaded with the software into the control module.

2. Press the **"Setup"** key to enter the Setup sub-menu.

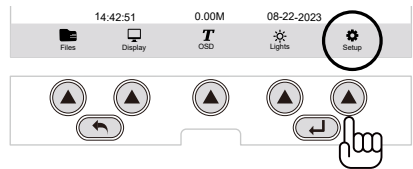

3. Press the **"System"** key to enter the System sub-menu.

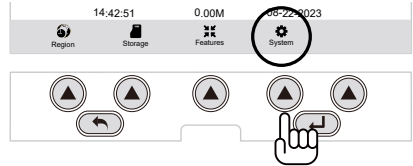

4. Use the **"Up/Down"** scroll keys to  highlight the firmware update file. Make a note of the current firmware version in the control module. It is shown to the right of the word "Version."

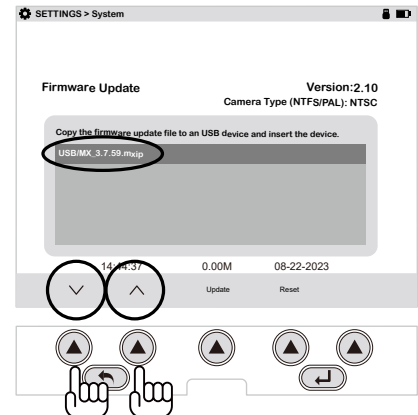

5. Press the on-screen "Update" key to  start the firmware update.

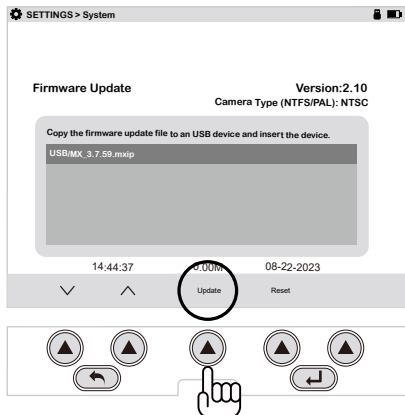

6. Let the update **run uninterrupted** until finished. During the update, the control module will **(7a)** load the files from the USB device, **(7b)** update the firmware chip in the control module, **(7c)** restart, **(7d)** finish updating the firmware files, then restart and return to the main viewing screen.

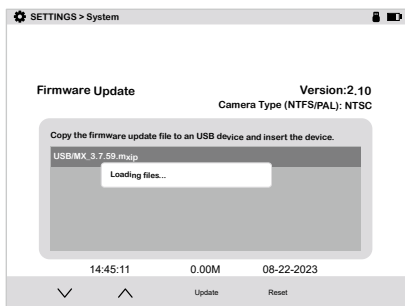

7a

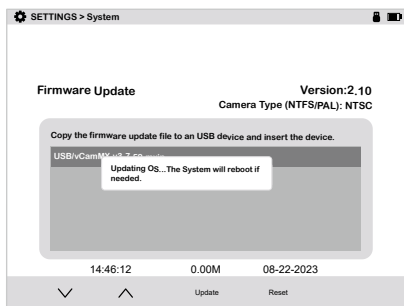

7b



7c

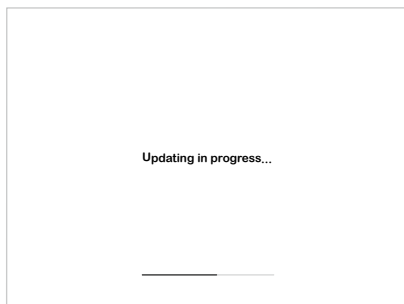

7d

7. During the update, the control module will reboot twice. Watch the progress indicators and let the system run until it returns to the main viewing screen. **(7e)**

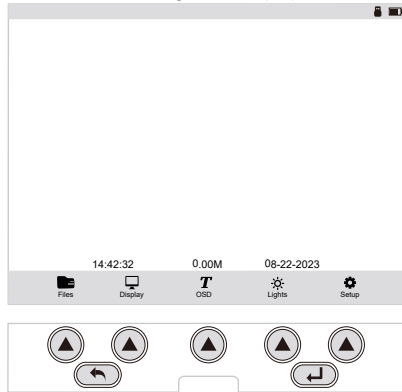

8. Confirm that the firmware update was successful by comparing the version after the update to the version number before. See step 5.

## 4. Video Recording and Image Capture

### 4.1 Overview

This chapter covers video recording, image capturing, reviewing files, and copying, moving and deleting video and picture files.

During a video recording, the following options can be used:

- Wi-Fi
- Sonde
- Microphone
- On-screen Text writer
- Camera LED control
- Distance counter reset
- Display color adjustments
- Take a JPEG image picture
- Pause the video for up to 30 minutes
- Use the digital zoom to view close-up (close-up view only; the zoom effect will not be recorded)
- Pushrod tracing (some interference may occur on the LCD)



**Use the Text Writer feature to add identifying text to the recording video and image captures. While looking at the preview in the file list sub-menu, the text recorded on the video and pictures will help identify the target video or picture.**

**Text can be added via the on-screen keyboard or the Wi-Fi app.**

### 4.2 Making a video recording

1. Press the **Record**  button to start the recording.

The button will glow red, and the record icon will appear on the status bar while recording.

If no USB thumb drive or SD card is inserted, a message will appear on the screen and the recording will not start.

If an SD card is present but no USB thumb drive, a message will appear advising that no USB drive is present, and the recording will go to the SD card.

2. Press the **Record**  button to stop and end the recording.

#### 4.2.1 Changing the File Name

When the Record button is pressed for the second time the video recording will end and the Save As dialog box will appear on the screen. Inside the dialog box, the system-generated file name will appear. The default file includes the Month, Day, Hour, Minutes and Seconds. To accept this file name, press the Enter button on the LCD.

**Save As** 1109\_04pm\_1427

Use the arrow keys on the control box to navigate the on screen keyboard.

**The system generated file name.**



**Press the Enter button to keep this name.**

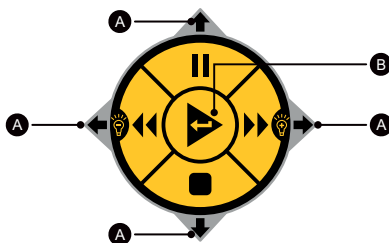

To change the file name use the Navigation Arrow buttons on the black control box to control the on-screen keyboard. Press the center Enter Key to select each letter.

- A** Navigation Arrow buttons
- B** Enter button

When finished entering the file name, navigate to the **Done Key (C)** and press the center **Enter button (D)** to save the file name.

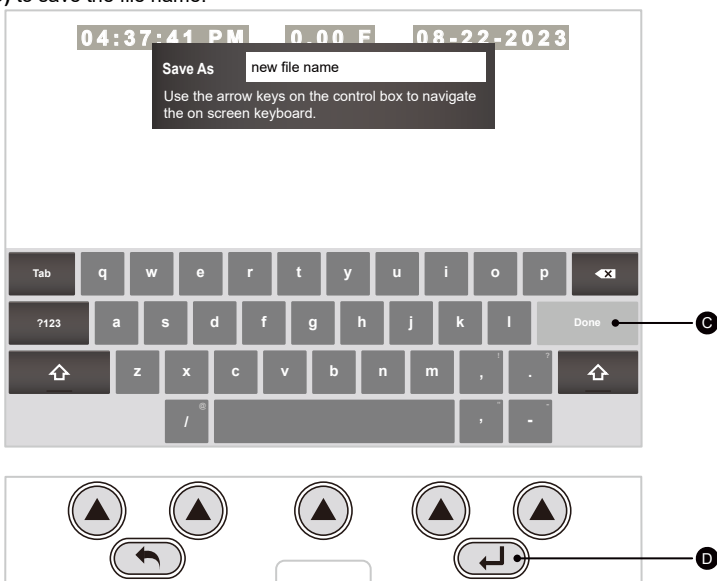

A dialog box will appear showing that the file name was successful.

File saved as: new file name1. mp4

#### 4.2.2 Taking JPEG Pictures

Press the JPEG button  to capture a JPEG image. The JPEG confirmation icon will splash on the screen, confirming the captured image. The file name is shown in the icon splash.

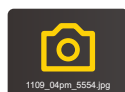

**JPEG Splash icon**

### 4.3 Viewing Recorded Videos and Pictures in the Control Module





#### 4.3.1 vCamMX-2+ File Manager Overview







- |                                     |   |
|-------------------------------------|---|
| 1 Status bar                        | 8 Play Key (Delete keys*)   |
| 2 Menu and sub-menu location        | 9 Graph showing the used and free space remaining of the USB drive or SD card |
| 3 File(s) select status             | 10 SD Card/USB drive information  |
| 4 File list                         | 11 Active file name   |
| 5 Scroll keys                       | 12 Preview window   |
| 6 Select file(s) key                | 13 Status bar   |
| 7 Select all file keys (Copy keys*) |   |

\* When multiple files are selected, the Select All and Play keys are replaced by Copy and Delete keys.

#### 4.3.2 Viewing and playing contents of the USB drive or SD Card

1. Press the File Manager Key to enter the file manager. 
2. Choose the drive where the files are located, SD or USB. 
3. Use the Up/Down Scroll Keys to highlight the desired file. 
4. Play - Press the Play Key to play the file. 

### 4.3.3 Copying files

1. Press the **Files** Key to enter the file manager. 
  2. Choose the drive where the files are located, **SD** or **USB**. 
  3. Use the **Up/Down Scroll** Keys to highlight the desired file(s). 
  4. Press the **Select** Key to individual files or press **Select All** to select all of the files.
  5. Select **Copy** to copy the selected file(s). 
- Select the copy destination, SD, or USB.

### 4.3.4 Deleting files

1. Follow steps 1 through 4 in section 4.3.3, Copying Files.
2. Press the **Delete** Key to delete the file(s). 



**Do not remove the SD or USB device from the control module while copying or moving files. This may result in creating corrupt unplayable files and the risk of corrupting the original file on the hard drive.**



**Only videos or pictures created in the control module will appear in the file list sub-menu and be viewed on the control module.**

## 4.4 MP4 Video Format

The vCamMX-2+ control module uses the MP4 video format. MP4 files were created under the ISO/IEC 14496-12:2001 standard by the ISO/IEC and Motion Picture Experts Group (MPEG). Because of this, MP4 is an international standard for audio-visual coding.

## 4.5 Troubleshooting Video Playback

If a video file can be played in the vCam control module, it will play on laptops or personal computers. If files cannot be played in the control module, the video file may become corrupt.

When files can be played in the control module but not on a PC, the following should be checked in this order.

**Default App and File Associations** tell the PC's operating system which software program to play the mp4 files from the control module. File associations must be set only once. They will stay until manually changed or when a major Windows update is run.

**Codecs** – the video and audio tracks in a file have been "encoded" or "coded" and must be "decoded" in the right way to play the file back. A media player, such as WMP (Windows Media Player), may require a specific codec to be installed to play a particular type of video file. Therefore, a codec is needed (Coder / Decoder).

**Corrupt Video Files** – some situations and circumstances may cause a video file to become corrupt. Third-party software may be able to help with this situation.

## 4.6 Corrupt Video Files

A file typically becomes corrupted when a problem occurs during the recording session, saving the file, or copying or moving the video file. If your control module loses power or crashes as you copy or move a file, there's a good possibility that the file will become corrupted.

Other possible causes of corrupt video files are:

- The USB or SD card was removed from the control module before the copy or move function could be completed.
- The control module loses power as the file is recorded, copied, or moved.
- The control module is dropped or moved to the USB drives to lose connection with the USB port as the file is recorded, copied, or moved.
- Using inferior quality USB drives or SD cards.

If a file is copied or moved from the control module and will not play on a PC:

- Check to see if the file will play in the control module. The file may have been corrupted during the move or copy process if it does not play. Try to recopy the file again making sure not to interrupt the process until it is finished.

If a file is copied or moved from the control module, it will play in the control module but not play on a PC:

- Try a different media player on the PC and try another PC. The mp4 video format used by the control module is a Microsoft format and should play in the Windows Media Player with no issues. If the file is not playing or playing incorrectly, there is a possibility that the correct video codec is missing. Computers running Windows 8 or higher will most likely have this codec installed by default, and a codec may need to be installed in older operating systems.

## 4.7 Other Media Players

There are several free video players available for download on the internet. These video players allow some advanced features that Windows Media Player may not have, such as playing several videos simultaneously to compare them and the ability to play multiple video formats. You can find these through an internet search on "Video Players."

A few of the more popular players are:

- The KM Player <http://www.kmpmedia.net/>
- VLC Player <http://www.videolan.org/>
- DivX Player <http://www.divx.com/>

**Vivax-Metrotech does not provide technical support for these players or Windows Media Player. Consult the manufacturer or your local IT department for technical support.**



**Vivax-Metrotech has manufactured the vCam-6 control module to produce video files and jpeg pictures compatible with the various Windows operating systems from Windows XP and later versions. Vivax-Metrotech cannot be responsible for the compatibility of all types of SD cards or USB drives. It is highly recommended that before these devices are purchased in bulk, they be tested for compatibility first.**

**Vivax-Metrotech cannot provide technical support for any device, Windows Media Player, security, and multi-media computer settings. Consult the manufacturer or your local IT department for technical support.**

## 5. Features Available During Recording

During a video recording, the following options are operational and usable:

- Wi-Fi
- Sonde
- Audio Commenting
- On-screen Text writer
- Camera LED control
- Distance counter reset
- Display color adjustments
- Take a JPEG image picture
- Pause the video for up to 30 minutes
- Use the digital zoom to view close-up (view only; the zoom effect will not be recorded)
- Pushrod tracing (some interference may occur on the LCD)

### 5.1 Voice Over

The voice-over feature will add audio comments to the recorded video. The control module has an internal microphone located right above the display.





The microphone on/off button



When the microphone is on, the icon is shown on the status bar.





1. Press the **Microphone** button on the front panel of the control module. The button will glow red when the microphone is on, and the microphone icon will be shown on the screen's status bar.
2. Speak clearly at a normal tone and volume towards the internal microphone above the display.
3. Stay between one and two feet from the internal microphone while speaking.
4. Press the **Microphone** button again to turn the microphone off.

### 5.2 Volume Control

During playback of the recorded video, the volume level can be adjusted. During video playback volume raise  **+** and lower icons  **-** are shown on the bottom left of the display. Use the corresponding keys to increase and decrease the volume.

### 5.3 Display and Backlight Settings

Pressing the **Display option from the LCD keypad** key anytime will bring up the color settings/backlight sub-menu. The color settings for the LCD can be made from this menu, and the backlight is adjusted.

1. Use the **up**  and **down**  arrow keys to move between the color settings selections.
2. Lower or raise the display settings using the **left**  and **right**  arrow keys.
3. When finished with the display adjustments, press the ESC key to return to the main on-screen menu.

### 5.4 On-Screen Status Bar

The status bar shows the battery status and active features such as the sonde, microphone, and Wi-Fi. The status bar is shown in all menus and sub-menus and is at the top of the display.

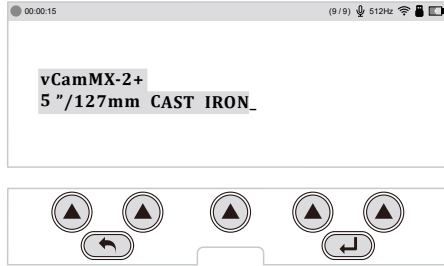

## 5.5 On-Screen Display (OSD Info)

The deployed pushrod's distance and the system's current date and time are shown on the screen and recorded in videos and pictures. The color of the OSD info can also be changed to suit the environment inside the pipe being inspected. By default, the OSD is positioned at the bottom of the screen and in white text.

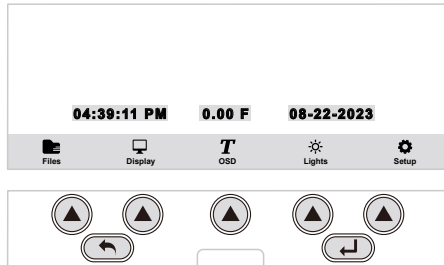

See section 3.2.1.7 to set the default position and colors of the OSD.

1. Press the **OSD** key to enter the OSD submenu.
2. Press the **Color** key to toggle through white, green, and yellow choices.
3. Press the **Position** key to toggle the position from bottom to top.
4. Press the **ESC** key to save the changes and return to the main on-screen menu.

## 5.6 Camera LED Light Control

The LEDs on the camera head can be adjusted in two ways.

### 5.6.1 From the Media Keypad

Use the left/right keys to lower and raise the camera lighting.

Use the keypad on the control box to raise and lower the camera's LED lighting.

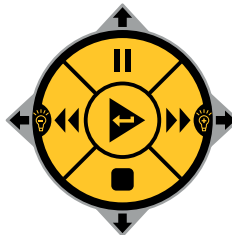

## 5.6.2 From the LCD Keypad

1. Press "Lights" to bring up the LED lights sub-menu.

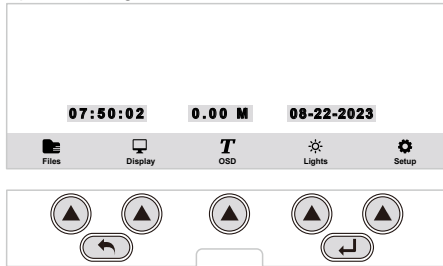

2. Use the corresponding karat keys to raise and lower the camera's LED lighting.

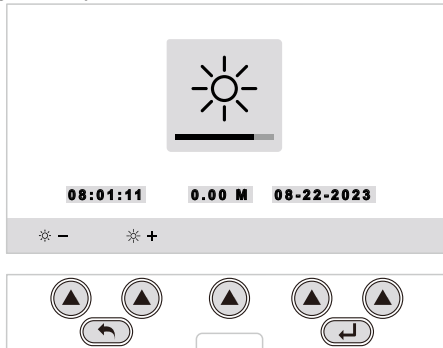

3. Press the ESC key to return to the main on-screen menu.

## 5.7 On-Screen Text Writer

### 5.7.1 Introduction to the On-screen Text Writer

The on-screen Text Writer function allows users to add descriptive text and comments, which will appear on recorded videos and pictures. The user can customize the text colors shown on the videos and pictures. The on-screen Text Writer has unlimited pages with 14 lines and 30 characters per line per page to be saved and later recalled for use.

The content from the on-screen Text Writer is saved into memory, so if the unit is turned off, the text will still be available when turned on again.

Alternatively, the free **vCam Mobile Controller (VMC)** app can add text to the screen with the mobile device's built-in keyboard.

Alternatively, a USB keyboard can be plugged into the MX and used.



**Text can also be added to the screen using the free vCam Mobile Controller app. Visit our website for more information and download links. Another option is a USB keyboard, which can be plugged into the USB port.**



**If the unit is reset to factory defaults, the saved pages of text will be lost. If the CMOS battery on the DVR circuit board is removed, all text will be lost. Only the text is saved into memory, and any colored text will be reset to the default white color.**

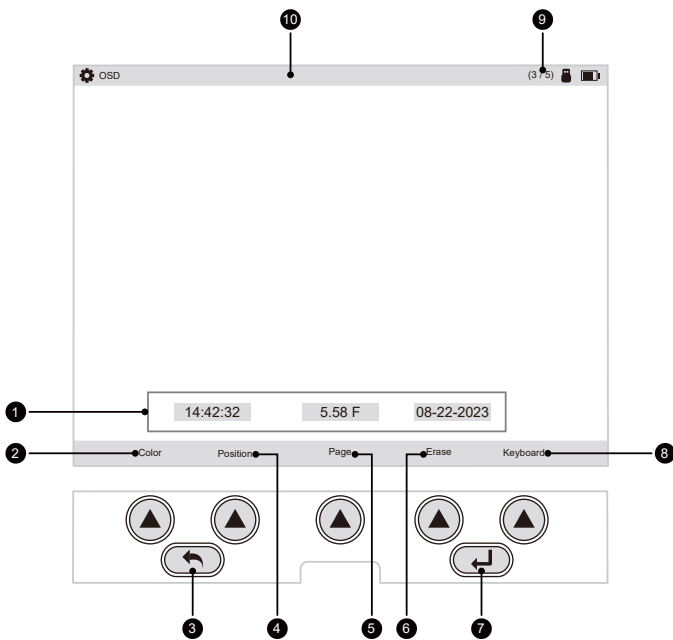

Figure 1

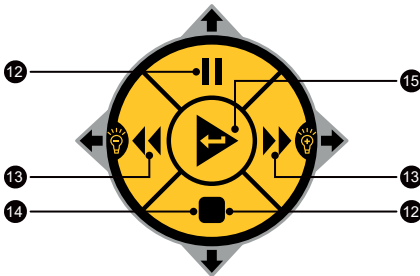

Figure 1a

## T OSD Sub-menu options

- 1 **OSD (On-Screen Display)** – Consists of the system's time, distance count, and date.
- 2 **Color** – Changes the text colors from white to black to yellow to green to red, then back to the default color of white.
- 3 **Position** – Moves the time/distance/date from the bottom to the top and then off.
- 4 **ESC** – Press to return to the previous screen or exit an operation.
- 5 **Page** – Scrolls through saved pages of text.
- 6 **Enter key** – Press this Key when required to complete an action.
- 7 **Erase** – Clears the current screen of all text and deletes the saved page.
- 8 **Keyboard** – Brings up the on-screen keyboard.
- 9 **Current page/Page number** – This shows the current page first and the number of saved pages. (current/saved) New text can be entered on the current page, identified by the character "-".
- 10 **Status bar** – The status bar shows the control module's running features, such as sonde and battery status. The current sub-menu location is also displayed.
- 11 **On-screen keyboard** – Use the keyboard to add and edit text on the screen.

### Navigating the on-screen keyboard



- 12 **Up/Down keys** – Use these keys to navigate up and down on the on-screen keyboard.
- 13 **Left/Right** – Use these Keys to navigate left and right on the on-screen keyboard.
- 14 **Show/Hide** – Use this Key to hide and show the on-screen text during a recording.
- 15 **Enter** – Use this key to select characters from the on-screen keyboard.



The on-screen keyboard option requires firmware version 1.4.8 or later.

#### To operate the on-screen keyboard:

1. Press the **“OSD” T** key from the main menu to enter the OSD sub-menu.
2. Press the **“Keyboard”** key to bring the on-screen keyboard to the screen.
3. Use the Rewind, Forward, Stop and Pause keys to navigate through the keyboard and use the Enter key (center) to select the text and numeric characters.
4. Press the **“ESC”** key to close the keyboard and return to the sub-menu. Press again to return to the Main Menu.

The on-screen keyboard can add six lines of text with 37 characters per line.

The text from the on-screen keyboard is **automatically saved** as it is entered. If the entered text is intended for one-time use, press the “Erase” Key before advancing to the next page of the text or turning the unit off.



The on-screen keyboard will never appear in any videos or pictures.



Use the pause key to pause the video while entering text. When finished, press pause again to resume recording.  
Use the Stop key to hide and show the current page of the text.

#### Status bar page information:

1. In this figure, the upper right-hand corner shows the page status on page 2 of 2 pages.
2. Text 2/ shows that the current page being edited is page 2.
3. The text /2 shows that two saved pages are in memory.

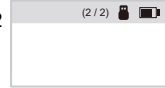

#### To erase saved pages of text:

1. Use the “Page” Key to scroll through the saved pages of text and stop at the page to be deleted.
2. Press the “Erase” Key; a dialog box confirms the page deletion.
3. Press the “Yes” Key to delete the page.
4. Press the “ESC” Key to close the keyboard and return to the main menu.



Text can also be added to the screen using the free vCam Mobile Controller app. Visit our website for more information and download links.



Darker colors may work better in pipes with water running through them. The lights from the camera head may reflect in the water, and white or yellow text may become washed out. Use a darker color and switch from light to dark when needed.



Use the Pause key on the top keypad to pause the video recording. With the video paused, use the up and down arrow keys to scroll through the saved pages of text and stop at the desired page. With the desired text being shown, un-pause the video to continue recording. At any time during the recording press the ESC key to clear the text from the screen.

## 5.8 JPEG Image Capture

1. Press the **Picture Capture**  key on the control box at any time.
2. The picture icon and file name will appear momentarily on the center screen confirming that the picture was taken and saved.
3. Pictures can be taken from live video while a recording is in progress or from a video played back in the control module.



Use the Text Writer feature to add identifying text to the recording video and image captures. While looking at the preview in the file list sub-menu, the text recorded on the video and pictures will help identify the target video or picture.

## 5.9 Digital Zoom

Use the zoom feature while viewing live, recorded, or JPEG captures.

1. Press the **Zoom**  button on the control box to activate the Zoom feature.
2. Repeated pressing will increase the zoom level to x2, x3, and then back to normal.



Note that the zoom feature is for viewing only and cannot be seen on recorded videos or pictures.

## 6. Wi-Fi

### 6.1 Wi-Fi Connection for Apps

The vCamMX-2+ control module has built-in Wi-Fi that broadcasts an SSID (secure network name) and uses DHCP (the protocol that assigns an IP address needed to connect to the control module) to assign IP addresses to a tablet or smartphone running the VMC app.

When connected to the **VMC** app, the control module's video stream is transmitted. The video stream will include any text on the app's screen, and the on-screen display will show the system time, distance count, and date.



**vCamMX-2+ firmware version of “4.4.76 and above can use the VMC app to perform Over the Air firmware updates. When the vCamMX-2+ control module is connected to the VMC app, the app can perform the firmware update.**

Visit our website at [www.vivax-metrotech.com](http://www.vivax-metrotech.com) for more information and download links.



**vCam Mobile  
Controller App icon**



**VMC Start Screen**

The VMC app is available from the Apple App or Google Play sites.



Android



iOS



## 7. Using the Reel

### 7.1 Pushrod Overview

The Pushrod Cable comprises a fiberglass rod surrounded by wire conductors and a Kevlar braid coated with a thick polypropylene jacket. Because of the harsh environment in which the pushrod is used, care should be taken to keep it in good operating condition.

**Check Pushrod for Wear** – Inspect the pushrod for cuts, kinks, and abrasions as it is retrieved back into the cable cage. If the jacket is cut or worn to the point that the yellow or white Kevlar braid can be seen, it is time to replace the pushrod. Using the pushrod with open cuts will result in water and moisture entering the pushrod and eventually traveling through it, causing a degraded camera image or total image failure.

**Keep the Pushrod and Termination Spring Assembly dry and clean** – When retrieving the pushrod, keep a dry rag in one hand and wipe down the pushrod as it moves through it. Use low-pressure water to rinse off the camera head and rinse away accumulated dirt and debris that may be caught in the spring. Shake dry or use low-pressure air to blow the excess water away and dry the parts. The Camera Head, Pushrod and Termination Parts are exposed to harsh chemicals in day-to-day use, and keeping a clean system will help prolong the life of these parts.

**Maintain proper control of the pushrod** – Attempting to pull the pushrod out of the reel while the reel is locked will result in the pushrod collapsing and stressing the pushrod. Pushing the pushrod back into the reel while locked may cause the reel to tip over or kink the cable.

**Rinse off the termination parts before the end of the day** – The camera and pushrod are subjected to a very harsh environment with possibly very caustic chemicals. If the parts are not cleaned off and are allowed to dry dirty, the chemicals may wear these parts prematurely. Use low-pressure water to rinse out the termination spring parts. Wipe dry or use air to blow off the water before storing it for the night or long periods. Removing the skid when storing it is good to prevent water from drying between the skid and the camera head.

#### 7.1.1 Distance Counter Accuracy

Follow these instructions for best results from the distance counter, starting with the control module **turned off**.

1. Rotate the cage to find the position of the sonde cup inside the cage.
2. Continue to rotate the cage until the position of the sonde cup is at the 9 O'Clock position.

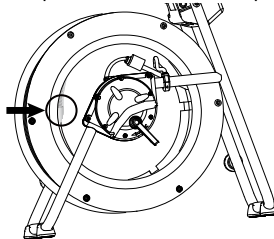

**Sonde cup at the 9 O'clock position inside the cage**

3. While holding the cage at 9 O'clock, reach into the cage and grab the spring assembly. Thread the Pushrod through the cable guide, as shown below.
4. Position the base of the sonde cup into the cable guide and lock the cage, as shown below. The sonde cup (a) is now in the cable guide at 12 O'clock, and the pushrod section from the cage to the sonde cup (b) is bent from the cage to the cable guide.

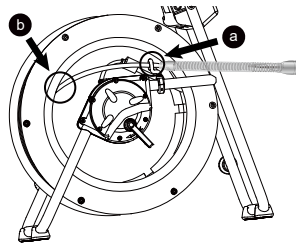

The sonde cup (a) in the cable guide at the 12 O'clock position

5. Power on the control module.

When the control module starts, it will see the position of the sonde cup as "zero."

### 7.1.2 Deployment of the Pushrod Cable



The friction brake should always be partially applied to slow cable deployment. Care should be taken to prevent the cable from unwinding uncontrolled to avoid injury.

Do not wear loose clothing that can become caught in a spinning reel. Keep hands away from a spinning reel.

1. Position the reel on a flat surface approximately 3 to 4 feet or 1 to 1-1/2 meters from the entry point. This will provide enough space to work with the Pushrod without much slack dragging on the ground. Use the friction brake to slow down the movement of the cable cage if needed. Using the reel in a horizontal position increases the width between the feet. This will give the reel more stability on uneven surfaces and lower the height in confined spaces.

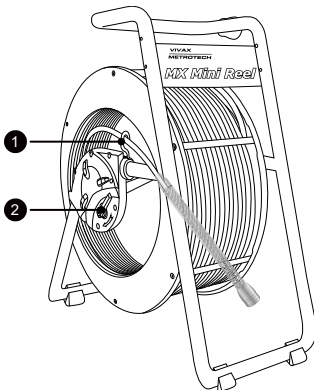

MX Mini Reel

- ① Cable Guide
- ② Locking Brake and Friction Brake

2. Turn the cable cage forward (clockwise) until the camera head is approximately at the 9 o'clock position.

3. Pull the termination spring out of the cage and enough Pushrod through the cage opening to thread the Pushrod into the cable guide.

4. The reel is now ready to be deployed into the pipe.

Before deploying the Pushrod, you should:



a) Remove any standing water from the pipe. The images will be much better if the camera head is not underwater.

b) Remove debris and objects from the pipe first. The camera is made to inspect the insides of pipes and not to clear or unblock them.

Use the Insertion Sleeve as much as possible to prevent the Pushrod from rubbing on sharp surfaces. Use devices such as a Tiger Tail when the entry point makes it impossible to use the Insertion Sleeve, such as inspecting lines in a utility hole.

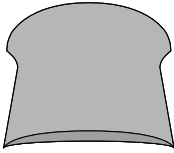

**Insert Sleeve**

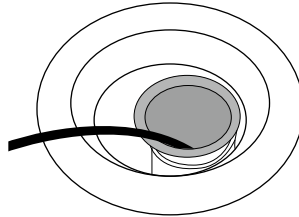

**Insert Sleeve in the cleanout**

Use "grip" type rubber gloves to better grasp and protect your hands from sludge during retrieval. The gripping action of the gloves will help keep a good hold on the Pushrod while deploying.

Apply the pushing force to the Pushrod as close to the entry point. Excess Pushrod between the point of entry and while pushing could kick the Pushrod. Never stand to use your weight to push on the Pushrod. Doing this may cause the Pushrod to kink.



**Proper placement and pushing force**



**Improper placement and pushing may result in kinking the Pushrod.**

Use finesse and not force when needed. The camera and Pushrod are made to travel through multiple bends within reason. If you are having trouble navigating through the pipe, try pulling the camera back four to eight inches and giving it a quick push-through. The quick pushing motion sometimes pushes the camera through a tight area. Never pull the camera head back and repeatedly ram it into the pipe to get through.

Run water in the pipe while inspecting. Inspect downstream with water running to lessen the pipe's friction and wash away dirt that may collect on the camera lens.

When having difficulties pushing, it may be better to do the recording on the way back so that the video recording does not waste time showing navigation through difficult areas. Record during the pullback and even slow strokes to pull back the Pushrod.

When accessing a “T” entry, use a string to bend the camera head and point it in the desired direction in the T. Be extra careful in T entries not to fold the camera back on itself; this could cause the camera to get stuck in the pipe.

Be sure to use the correct model camera in the right size pipe. Using a camera that is too big may cause it to get stuck; using a camera that is too small will result in poor lighting and video quality.

Use a skid on the camera head. A skid will protect the camera head from directly hitting debris and offsets, but it will also keep the camera head off the pipe floor and better centered within it. Keeping the camera head off the floor of the pipe will also improve the picture quality because the light from the camera will be more evenly spread in the pipe. Various types of skids are available for different applications. See the section of this manual covering accessories, or visit our website for more skid information.

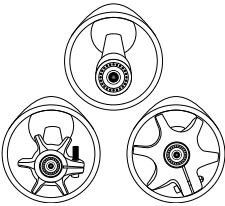

With no skid, the camera head sits on the pipe floor. The camera head comes into contact with silt and debris in the pipe.

Using a skid lifts the camera head off the floor to help avoid silt and debris on the pipe floor.

When retrieving the Pushrod, take care and try to lay the rod in the cage in layers while wiping the rod free of water and debris.

## 8. Camera Heads and Terminations

### 8.1 Parts of the Camera Heads

#### D18-HD and D26-HD Cameras for the Type-MX Mini Reel

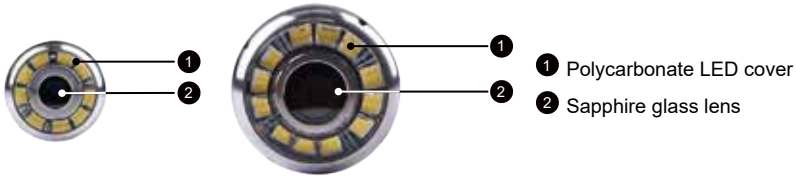

#### Camera Head Face

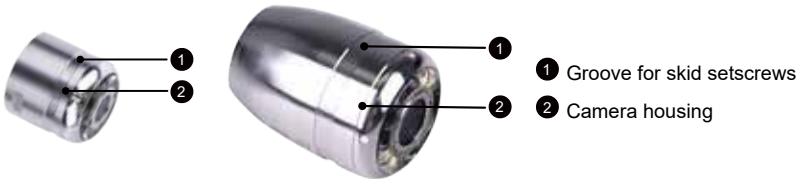

#### Camera Head Body

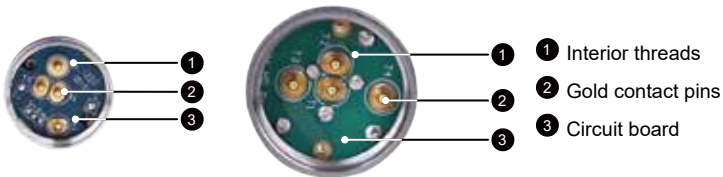



#### Camera Head Rear

#### 8.1.1 Camera Head Options

The vCamMX series camera heads are available in three sizes for various applications. Choosing the proper camera depends on the pipe diameter to be inspected.

All camera heads ship with a protective “standard skid” installed.

### Camera Head Options for the Type-MX Mini Reel

Camera Heads	Leveling	Description	Pipe Size Range
 D18-HD	Non-leveling	18mm / 0.76" diameter	1.5" to 3" / 38mm to 75mm
 D26-HD	Self-Leveling	26mm / 1" diameter	2" to 4" / 50 to 100mm

**Contact a local Vivax-Metrotech distributor or local office for ordering information, applications, compatibility, and pricing.**

## 8.2 Spring Termination Parts



The Spring Termination Assembly is comprised of the parts that connect the camera head on one end and are connected to the Pushrod on the other. The termination spring assembly for the MX reel is an all-in-one assembly consisting of a spring, coiled cable, and lanyard preassembled.



- ① Camera End with Circular Circuit Board
- ② Spring Assembly with Coiled Cable and Lanyard
- ③ Pushrod End with Push Pins

**MX Mini Termination Spring Assembly**

### 8.2.1 Termination Parts List

Picture	Description	Comments
	Spring assembly O-Ring, 14mm x 1.5mm, NBR	Two are required, one at each end.
	MX Spring Assembly	An all-in-one assembly consisting of spring, coiled cable and lanyard preassembled

**Contact a local Vivax-Metrotech distributor or local office for ordering information, applications, compatibility, and pricing.**

### 8.2.2 Pre-checking the Camera Head Before Installing

If the occasion should arise where a camera head must be re-installed or replaced, pre-check these items before the camera is fully installed. The visual checks can be done in an area with good lighting using a magnifier, and some checks are better done with the camera LEDs turned on.

### 8.2.3 Pre-checking for Picture and LED Control

Visually check the circular connector in the camera base for deep scratches, dirt, or corrosion. Attach the camera to a reel and power on the control module. Through the control module, check for a good picture, that the LED lights are on, that the camera works, and that you can control the LED lights.

### 8.2.4 Pre-checking the Camera Glass Lens and LED Cover

This pre-check is better done with a control module attached to a reel or by the camera test port. For this pre-check, the LED lights should be on so that the camera face can be better examined.

#### Pre-checking the LED Cover

The Polycarbonate LED cover is the section of the face of the camera that covers the LEDs. Visually check the inside and outside radius for chips and cracks.



#### Sapphire Glass Lens

The Sapphire Glass camera lens is the center clear glass section of the camera face. Visually check the surface of the glass for scratches. Visually inspect the outside radius for chips and cracks.



**Contact the factory or your local dealer if you see cracks or chips on the lens.**

### 8.3 Removing and Installing the Camera Head

Do not touch the green circuit board or gold pins on the spring assembly or camera head with bare hands. Touching these will transfer oils from the fingers to these components, leading to premature corrosion. Wear clean rubber gloves if possible.

The vCamMX-2+ is supplied with tools for camera and spring removal and installation.



1. **D20-HD** – Use on the flats of the D18-HD and D20-HD camera heads.
2. **TERM KIT** – Use on the flats on the Spring Assembly.
3. **D26-HD** – Use on the flats of the D26-HD camera head.

### Camera head removal

1. Use the section of the tool labelled TERM KIT to hold the flats on the spring.

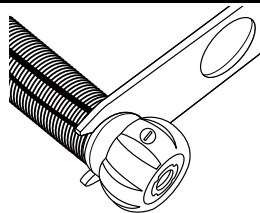

2. Place the section of the other tool labelled D26-HD or D20-HD on the camera head flats and turn counterclockwise until the camera is loosened.
3. Proceed to unscrew the camera head by hand until it is removed.

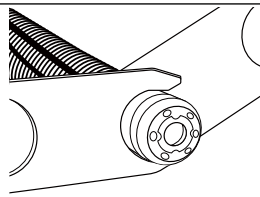

### Camera head installation

Remove any excess dirt that might contact the gold pins or green circuit board. Check that the O-ring is in good condition. Wipe the circuit board in the spring and camera contact pins with an alcohol wipe or swab.

1. Use the section of the tool labelled TERM KIT to hold the flats on the spring.
2. Screw on the camera head by hand until the O-ring is engaged.

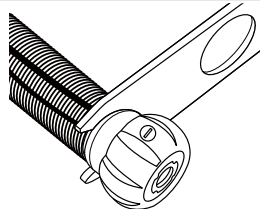

3. Use the section of the tool labelled D20-HD or D26-HD of the other tool on the camera head flats and turn clockwise **until the O-ring is no longer visible**.

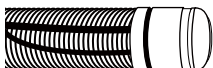
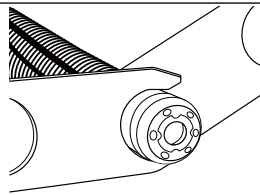

Visible O-Ring



O-Ring is no longer visible

### 8.4 Removing and Installing the Spring Assembly

Don't touch the green circuit board, gold pins on the spring sonde assembly, or camera head with bare hands. Touching these will transfer oils from the fingers to these components, leading to premature corrosion. Wear clean rubber gloves if possible.

1. Remove the camera head following the instructions shown in section 8.3.

2. Firmly hold the knurled base kit with one hand.

3. Apply the section of the tool labeled TERM KIT to the flats of the Spring Assembly.
4. Turn the tool counterclockwise to loosen and remove the spring assembly.

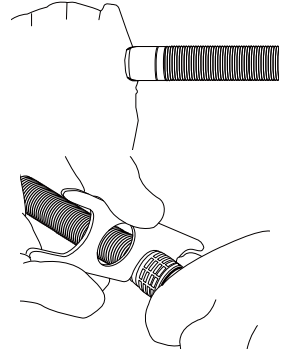

**Installing:** Remove any excess dirt that might get onto the gold pins or green circuit board. Check that the O-rings are in good condition.

1. Firmly hold the knurled base kit with one hand.
2. Screw on the spring buy hand until the O-ring is engaged.

3. Use the tool section labelled TERM KIT and continue to screw on the spring while holding the knurled base kit.

4. Tighten with the tools until the O-Ring is no longer visible.

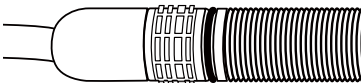
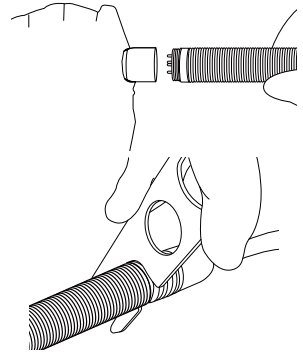

Visible O-Ring

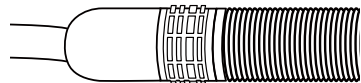

O-Ring is no longer visible

## 9. Camera Skids

### 9.1 Camera Skids

Camera skids are devices that attach to the camera head to 1) keep the camera head off the floor of the pipe to help avoid pushing up debris and dirt, which will end up on the camera lens, blocking your view, and 2) allow the camera LED lighting to function better by keeping the lights more centered in the pipe allowing a more even spread of light on the pipe walls and ahead and 3) protect the camera head by giving a shoveling effect which allows the camera head to be lifted over offsets and objects which helps prevent the camera head from making direct contact with them. Lastly, the skids will help increase the camera's and Pushrod's pushing distance by providing a more non-binding material to slide against plastic, clay, metal, and cement pipes. There are a variety of skids for specific uses and camera sizes and a few different methods of attaching the skids to the camera system.

### 9.2 Camera and Spring Skids, Installing and Removing



Standard Skid



Guide Skid



Clip together Skid

#### 9.2.1 Standard Skid, Screw in Setscrews D18 series and D26-MX

The standard skids ship installed on the camera head.

**Tools Needed:** 3mm/1/8-inch flat screwdriver.

1. Use the screwdriver to back out the three screws so the camera head will slide unobstructed into the skid.
2. Slide the camera head into the skid until the head is flush with the front.
3. Use the screwdriver to secure the standard skid to the camera head.

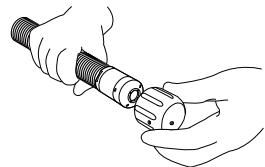
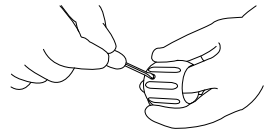

**Do not overtighten the screws. This may result in stripping the screw threads or damaging the camera housing.**



Apply a layer of electrical tape over the screw holes on the installed skid. This will help keep debris from filling the screw slot, making removing them easier.

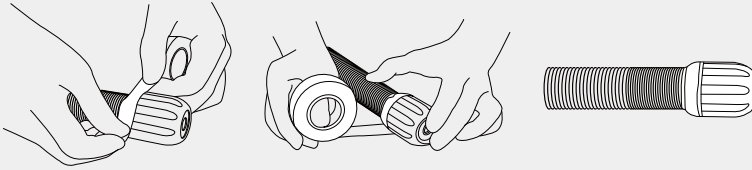

### 9.2.2 Standard Skids, Two-part Clip Together D26-HD

**Tools Needed:** No tools are needed

1. Press in on the locking tabs while pulling the two parts apart.



2. Remove the camera from the spring and slide the rear of the skid onto the spring with the tabs facing forward.

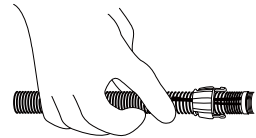
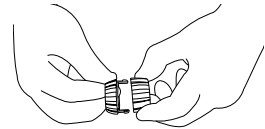

3. Install the camera head onto the spring. Ensure that the camera head is installed correctly by using the camera tools and tightening it until the O-ring is no longer visible.

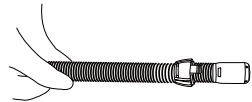

4. Slide the front of the skid over the camera head, aligning the locking tabs with the receptacles.

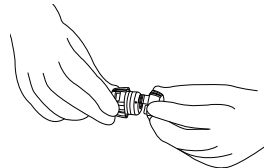

5. Press the two skid halves together until the tabs lock into the receptacles.

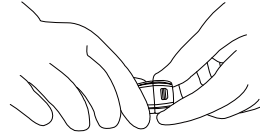

### 9.2.3 Guide Skids, Clamp around the Camera Head

Some vCam series skids will come with a removable rubber front guard. The removable rubber front protects the camera; it should contact objects such as offsets. Over time, the rubber guard will wear and then be replaced with a new rubber front guard. Follow these directions to change the rubber front guard.

#### Guide Skids, Clamp around the camera head

##### D18 and D26 series

**Tools Needed:** 5mm Hex wrench

1. Use a hex key and loosen the screws so the skid will slide unobstructed onto the camera head.
2. Slide the camera head into the skid until the head is flush with the front.
3. Use a hex key to secure the skid to the camera head.
4. Check that the skid is secure by turning and pulling it simultaneously.

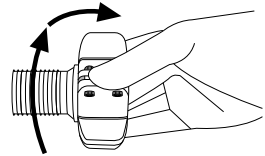
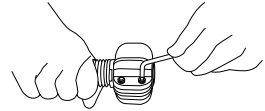
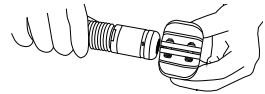
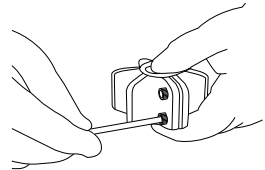

**Refrain from attempting to close the guide skid fins together completely. Doing so can result in damage to the camera head or the skid.**

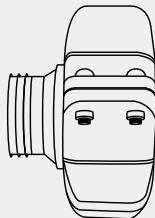
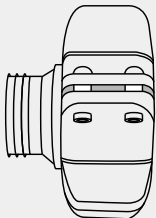

## 10. Locating the Camera Sonde and Pushrod



Always “Call Before You Dig” and follow your company’s safety practices and local, state, and national regulations.

The Type-MX reel includes a locatable sonde in the termination assembly and a contact post on the reel for tracing pushrod with an external transmitter.

Vivax-Metrotech manufactures a range of utility locators and sonde locators. Information and instructions on these locators can be found on our website or by contacting your local distributor.

For operating instructions and information on the vLoc3-Cam sonde locator, visit our website at [www.vivax-metrotech.com](http://www.vivax-metrotech.com).

### 10.1 Sonde Operation

1. Press the Sonde button on the control box to activate it. The LED in the sonde button will glow, an icon will momentarily appear on the screen with the frequency, and the sonde frequency will appear on the status bar.  
If more than one frequency was selected in the sonde setup, pressing the sonde button again will switch to the second frequency. (see section 3.2.1.6 Set the sonde frequency).
2. Press the Sonde button to turn the Sonde off.



Turn the sonde off when not in use to save battery life.

### Sonde Locating

The best practice for locating the camera sonde is to push the camera into the pipe, and when it is level, stop and do the locate. From then on, work in 10 to 20-foot increments, stopping every 10 to 20 feet and locating the sonde. It is not a good practice to push the camera into the pipe a great distance away and set out to locate it. The distance counter in the control module will estimate how far the camera has been deployed, but this is just for reference.

### 10.2 Applying a Locate Signal onto the Pushrod

A utility locator transmitter is required to locate the Pushrod. Frequencies starting at 33kHz and above will work better than lower frequencies.

1. Lock the cable cage by using the brake lock.
2. Connect the red-colored hot lead from the transmitter to the contact post on the Type-CP or MX reel. Refer to the diagrams in section 2.4 for the reel contact post location.
3. Place the utility locator transmitter:
  - a) Out of the reel’s general work area.
  - b) To prevent the leads of the transmitter from becoming tangled in the spinning reel cage.
  - c) So that the leads from the transmitter do not cross over the Pushrod path in the pipe.
4. Insert the transmitter’s ground stake in the earth approximately five feet at a right angle to the reel.



5. Turn on the utility locator transmitter and select a frequency. We recommend using a higher frequency, such as 65kHz or 83kHz. Ensure that the transmitter has good ground. The better the ground, the better the locator will perform.
6. Use the utility locator in the line mode, not sonde mode, to trace the path of the Pushrod underground.

# 11. Troubleshooting

Please check the Knowledge Center on the Vivax-Metrotech website for the latest support information.

Go to [www.vivax-metrotech.com](http://www.vivax-metrotech.com) and then click **Support**, then **Knowledge Center**.



## Problem: No power. The unit will not turn on:

### Check:

1. Check to see if the fuse is installed, blown, or damaged. The unit will not charge your battery if the fuse is not installed.
2. Try using mains current and not battery to turn on the unit. If the unit does power on with mains current, your battery is not charged, which may be why it will not.
3. While the unit is charging, see if the battery icon on the front panel is glowing red, or if turned on, you see a lightning bolt inside the battery icon on the bottom right corner of the LCD.

## Problem: Not recording:

### Check:

1. Check the battery level. The unit may not have enough power to record when the battery is low.
2. Check the available disk space on the USB drive.

## Problem: Sonde not working:

### Check:

1. Check the control module's battery level. When the battery is low, the sonde may not operate.
2. Check that the sonde frequency in the control module matches that of the sonde locator.

## Problem: The distance counter is not accurate:

### Check:

In the menu settings for reels, check:

1. Check if the distance counter setting is set to Meters or Feet.
2. Check that the friction brake is not slowing the cage so much that it jerks in and out.
3. Refer to section 7.1.1 of this manual.

**Problem: Interference or noise on LCD:****Check:**

In some circumstances, the Sonde can cause interference in the video being viewed or recorded. The Sonde is recommended to be turned off unless it is being used for location.

**Problem: USB or SD device not recognized:****Check:**

1. Make sure the media device is working and not corrupt.
2. Try formatting the device in the control module.
3. Read the section in this manual, "File Format of SD Cards and USB Drives."

**Problem: No audio being heard on the recorded video:****Check:**

1. Check that the volume is turned up during playback. Use the key function **Ctrl -** to lower the volume and **Ctrl +** to raise the volume.
2. Ensure that the red microphone icon is on the status bar and that the microphone button is illuminated during the audio recording.
3. Assure that the audio comments were directed toward the internal microphone between one and three feet from the internal microphone.

**Problem: Dark or hard-to-view display:****Check:**

1. Check that the camera's LED lights are turned on.
2. Press the Display key on the main on-screen menu and check the brightness and backlight settings.

.....

Illustrations used in this manual's preparation will inevitably show some resemblance to similar images from other manufacturers. These manufacturers have permitted the use of their graphics, and this statement is intended to attribute such credit.

.....

The Bluetooth® word mark and logos are registered trademarks owned by Bluetooth SIG, Inc.  
iOS is a Cisco Systems, Inc. trademark registered in the U.S.  
Android, Google and Google Maps are registered trademarks of Google LLC.  
DROPBOX is a registered trademark of DROPBOX, Inc.  
BOX Software is a registered trademark of BOX, Inc.  
OneDrive and OneNote are registered trademarks of Microsoft.  
Wi-Fi is a trademark of the Wi-Fi Alliance.

**Disclaimer:** Product and accessory specifications and availability information are subject to change without prior notice.





Online Manual

**Vivax-Metrotech Corporation**

3251 Olcott Street, Santa Clara, CA 95054, USA

Toll-Free: 1-800-446-3392

Phone: +1 (408) 734-3880

Website: [www.vivax-metrotech.com](http://www.vivax-metrotech.com)